

**HP 8960 Series 10 E5515A Wireless Communications Test Set
HP E1960A GSM Mobile Test Application**

HP-IB Command Syntax

<http://www.hp.com/hp8960support/>

Test Applicatin Revision A.01

© Copyright Hewlett-Packard 1999

Printed in U.S.A. March 1999

HP Part Number: E1960-90003

Revision C



**HEWLETT®
PACKARD**

Notice

Information contained in this document is subject to change without notice.

All Rights Reserved. Reproduction, adaptation, or translation without prior written permission is prohibited, except as allowed under the copyright laws.

This material may be reproduced by or for the U.S. Government pursuant to the Copyright License under the clause at DFARS 52.227-7013 (APR 1988).

Hewlett-Packard Company
Learning Products Department
24001 E. Mission
Liberty Lake, WA 99019-9599
U.S.A.

Contents

Developing Code	11
Units-of-Measure	11
Diagram Conventions	11
ABORt	13
AFGenerator	14
CALibration	15
CALL:ACTivated	16
CALL:BA	17
CALL[:CELL]:BA:TABLE	17
CALL[:CELL]:BA:TABLE:POINTs	18
CALL:BAND	19
CALL:BCCode	20
CALL:BCHannel	21
CALL:BURSt	22
CALL:CONNected	23
CALL:COUNt	24
CALL:END	25
CALL:FUNCtion	26
CALL:IMEI	27
CALL:LACode	28
CALL:MCCode	29
CALL:MNCCode	30

Contents

CALL:MS	31
CALL:MS:DTX	31
CALL:MS:REPorted<:CLEar :IMEI? :IMSI? :LACode :MCCCode? :MNCCode? :NEIGHbour> 31	
CALL:MS:REPorted<:ONUMber? :PCLass? :REVision? :RXLevel :RXQuality>	32
CALL:MS:REPorted<:SBANd? :TADVance :TXLevel>	33
CALL:MS:TADVance	34
CALL:MS:TXLevel	34
CALL:NCCode	35
CALL:OPERating	36
CALL:ORIGinate	37
CALL:PAGing	38
CALL:PMNCode	39
CALL:POWER	40
CALL:RFGenerator	41
CALL:RFGenerator<:CHANnel :FREQuency>	41
CALL:RFGenerator:POWER	42
CALL:STATus	43
CALL:TCHannel	44
CALL:TCHannel	44
CALL:TCHannel<:DCS :EGSM :PCS :PGSM>	45
CALL:TCHannel:BAND	45

Contents

CALL:TCHannel<:DOWNlink :LOOPback :TSLot>	46
DISPlay	47
FETCh:AAUDio	48
FETCh:BERRor	49
FETCh:BERRor<:BITS :DELay :COunt :INTegrity>?	49
FETCh:BERRor:COunt	50
FETCh:BERRor:RATio	51
FETCh:DAUDio	52
FETCh:FBERRor	53
FETCh:ORFSpectrum	54
FETCh:ORFSpectrum<:ICOunt :INTegrity :MODulation :POWER>?	54
FETCh:ORFSpectrum:SWITching	55
FETCh:PFERRor	56
FETCh:PFERRor<:FERRor :ICOunt :INTegrity>?	56
FETCh:PFERRor:PEAK	57
FETCh:PFERRor:RMS	57
FETCh:PVTime	58
FETCh:PVTime<:ICOunt :INTegrity>?	58
FETCh:PVTime:TXPower	58
FETCh:PVTime:MASK	59
FETCh:PVTime:POWER	60
FETCh:TXPower	61

Contents

INITiate	62
INITiate:<measurement mnemonic>	62
INITiate:<COUNT? :DONE :ON?>	63
READ	64
RFANalyzer	65
RFANalyzer:CONTRol	65
RFANalyzer:EXPEcted	65
RFANalyzer:MANual	66
SETup:AAUDio	67
SETup:AAUDio<:CONTInuous :COUNT :EXPEcted>	67
SETup:AAUDio<:FILTEr :TIMEout>	68
SETup:BERRor	69
SETup:BERRor<[:TYPE] :CONTInuous :COUNT>	69
SETup:BERRor<:LDControl :MANual :TIMEout>	70
SETup:CONTInuous	71
SETup:DAUDio	72
SETup:DAUDio<:CONTInuous :COUNT>	72
SETup:DAUDio<:FILTEr :TIMEout>	73
SETup:FBERRor	74
SETup:ORFSpectrum	75
SETup:ORFSpectrum<:CONTInuous :COUNT :ICount>	75
SETup:ORFSpectrum:MODulation	76

Contents

SETup:ORFSpectrum:SWITChing	77
SETup:ORFSpectrum:TIMEout	78
SETup:ORFSpectrum:TRIGger	78
SETup:PFERror	79
Syntax Diagrams and Command Descriptions	79
SETup:PFERror<:BSYNc :CONTInuous :COUNt>	79
SETup:PFERror:TIMEout	80
SETup:PFERror:TRIGger	80
SETup:PVTime	81
SETup:PVTime<:BSYNc :CONTInuous :COUNt>	81
SETup:PVTime:TIME	81
SETup:PVTime:TIMEout	82
SETup:PVTime:TRIGger	82
SETup:TXPower	83
SETup:TXPower<:CONTInuous :COUNt>	83
SETup:TXPower:TIMEout	83
SETup:TXPower:TRIGger	84
STATus:OPERation	85
STATus:OPERation	85
STATus:OPERation:CALL	86
STATus:OPERation:NMRReady	87
STATus:PRESet	88

Contents

STATus:QUEStionable	89
STATus:QUEStionable	89
STATus:QUEStionable:CALL	90
STATus:QUEStionable:ERRors	91
STATus:QUEStionable:HARDware	92
SYSTem:BEEPer	93
SYSTem:COMMunicate	94
SYSTem:CORRection	95
SYSTem:CURRent (future functionality)	96
SYSTem:ERRor	97
SYSTem:FTRigger	98
SYSTem:MEASurement	99
SYSTem:PRESet	100
SYSTem:ROSCillator	101
SYSTem:SYNChronized	102
HP-IB IEEE 488.2 Common Commands	103
*CLS	104
*ESE	104
*ESE?	104
*ESR?	104
*IDN?	104
*OPC	105

Contents

*OPC?	105
*OPT?	105
*RST	106
*SRE	107
*SRE?	107
*STB?	107
*WAI	107

Contents

Developing Code

It is recommended that you set the Test Set's operating environment to debug. To set the Test Set debug mode to "ON" use the following syntax:

```
SYSTem:COMMunicate:GPIB:DEBug ON
```

Units-of-Measure

If you do not specify units-of-measure in your code the following table indicates the default units-of-measure that will be assumed.

Amplitude (linear)	V
Frequency	HZ
Power (logarithmic)	dBm
Time	S

Diagram Conventions

Use the following diagram to see the conventions used in the syntax diagrams.

Statement elements are connected by lines. Each line can be followed in only one direction, as indicated by the arrow at the end of the line. Any combination of statement elements that can be generated by starting at the **Root Element** and following the line the **proper direction** is syntactically correct. The drawings show the proper use of spaces. Where spaces are required they are indicated by **<sp>**, otherwise no spaces are allowed between statement elements.

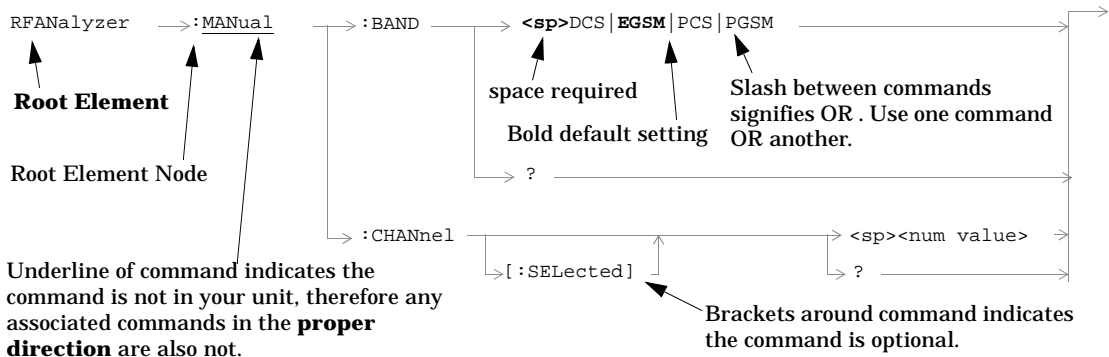

ABORt

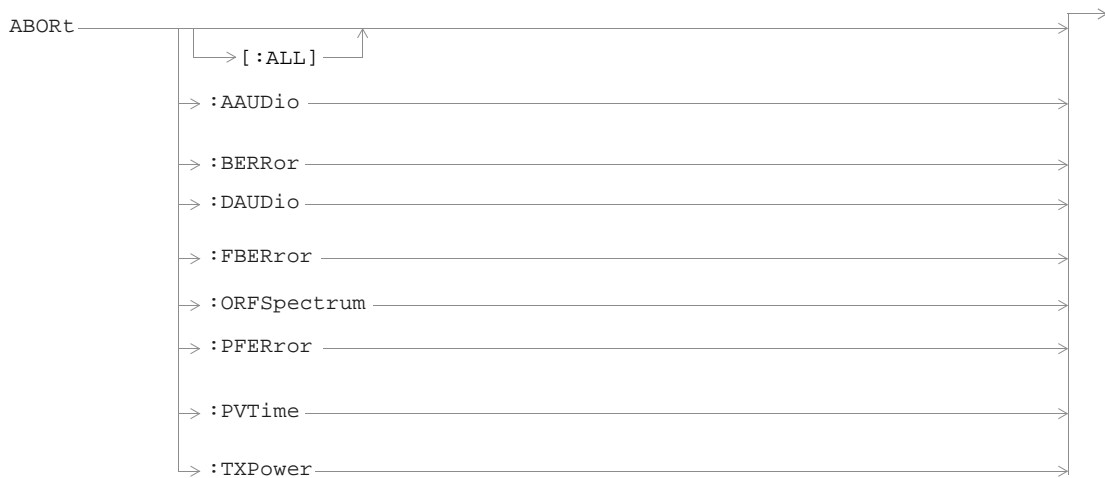

AFGenerator

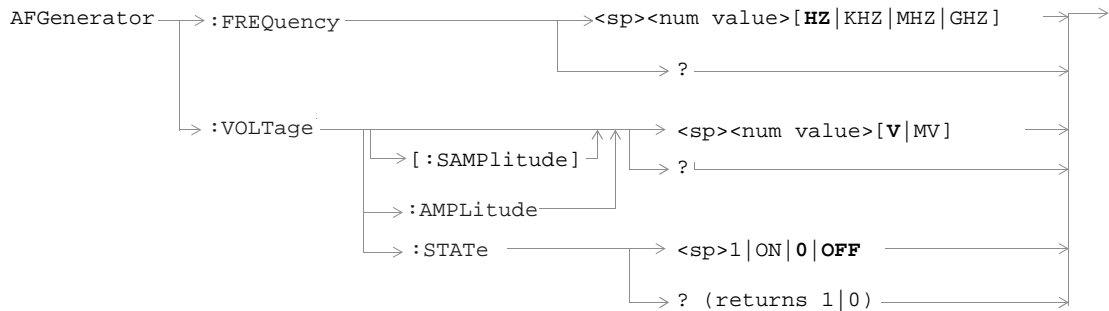

CALibration

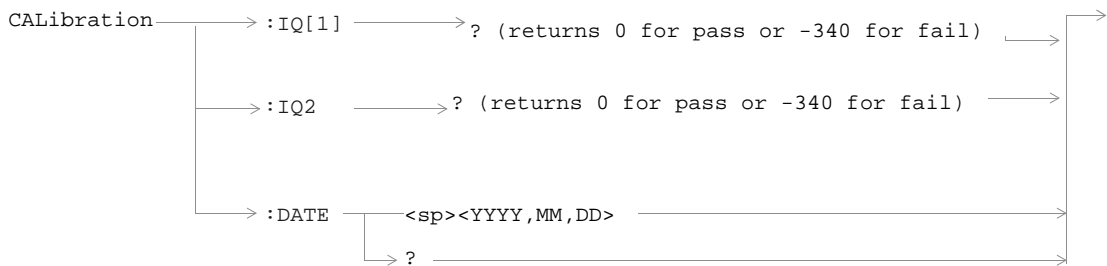

CALL:ACTivated

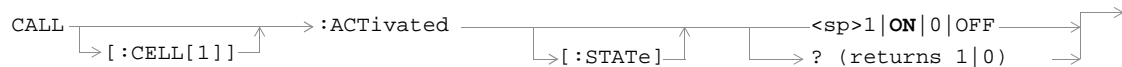

CALL:BA

CALL[:CELL]:BA:TABLE

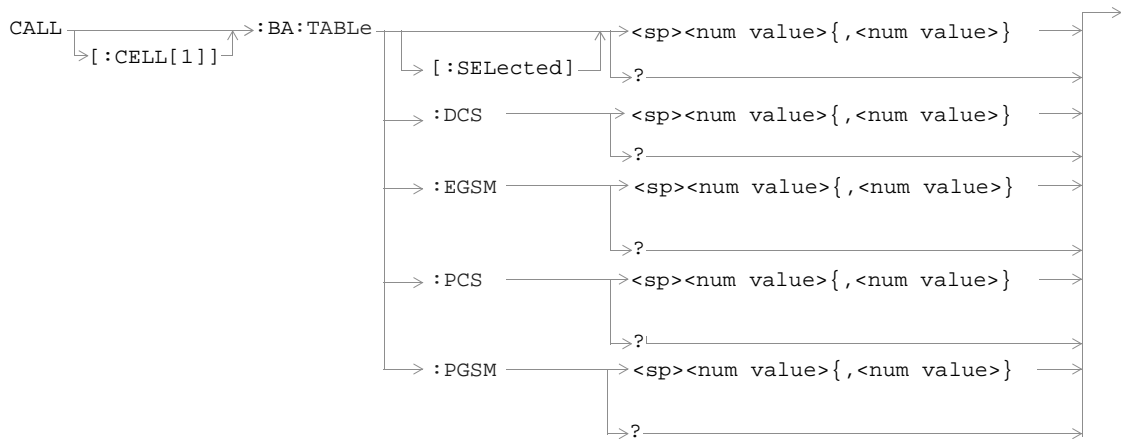

CALL[:CELL]:BA:TABLE:POINTs

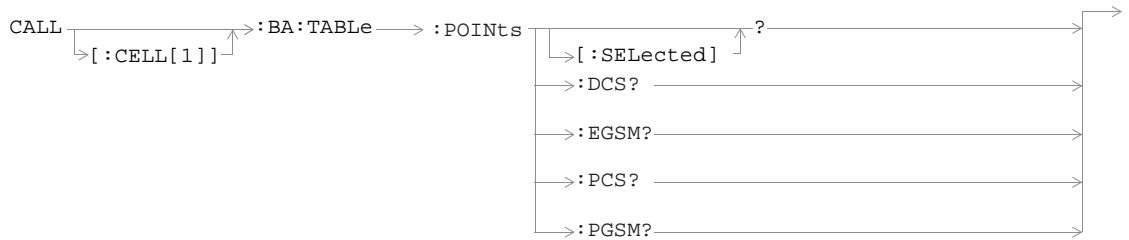

CALL:BAND

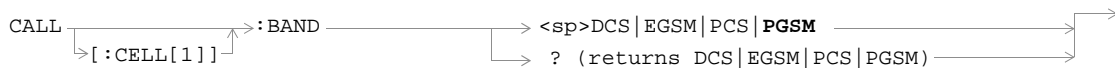

CALL:BCCode



CALL:BCHannel

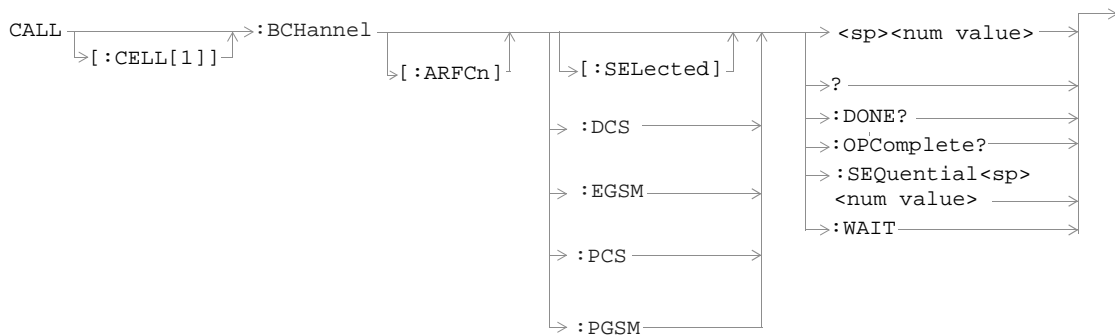

CALL:BURSt



CALL:CONNECTed

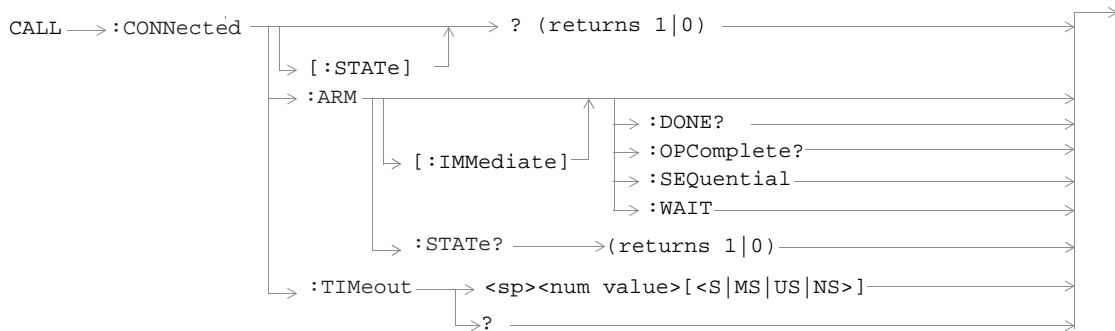

CALL:COUNT

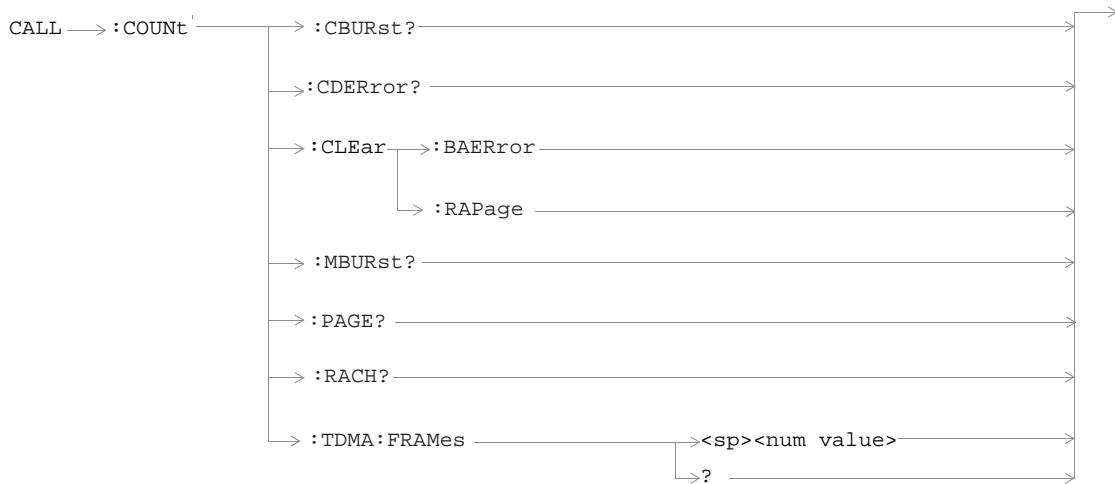

CALL:END

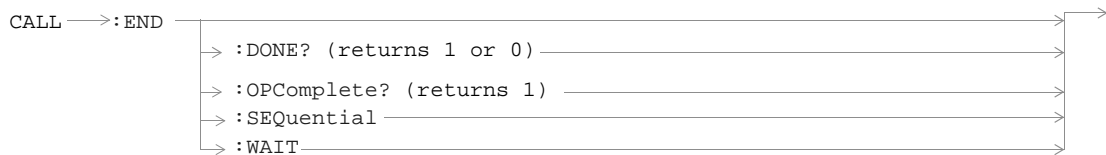

CALL:FUNction



CALL:IMEI

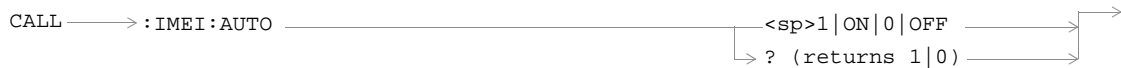

CALL:LACode

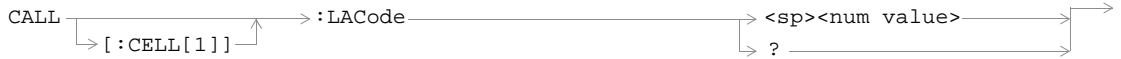

CALL:MCCode

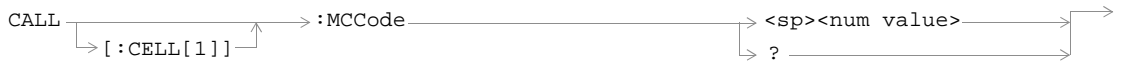

CALL:MNCode

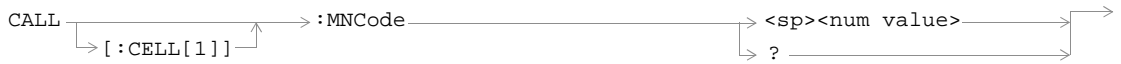

CALL:MS

CALL:MS:DTX

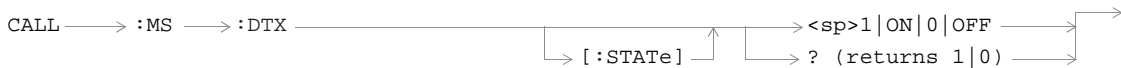

CALL:MS:REPorted<:CLEar | :IMEI? | :IMSI? | :LACode | :MCCCode? | :MNCCode? | :NEIGHbour>

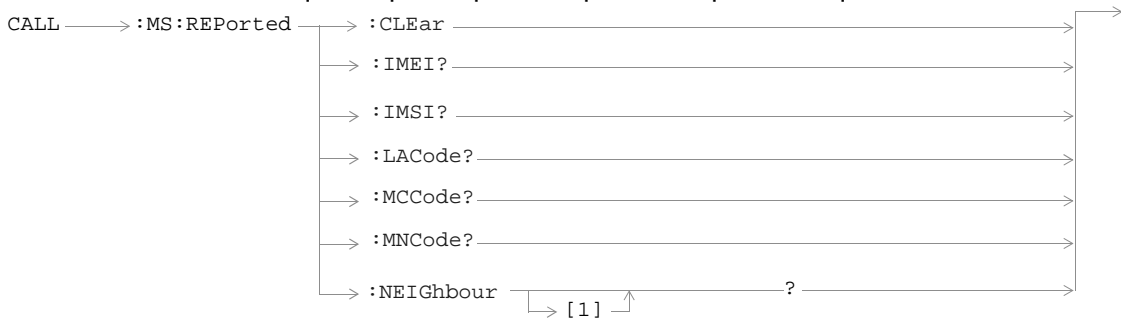

CALL:MS:REPorted<:ONUMber? | :PCLass? | :REVisiOn? | :RXLevel | :RXQuality>

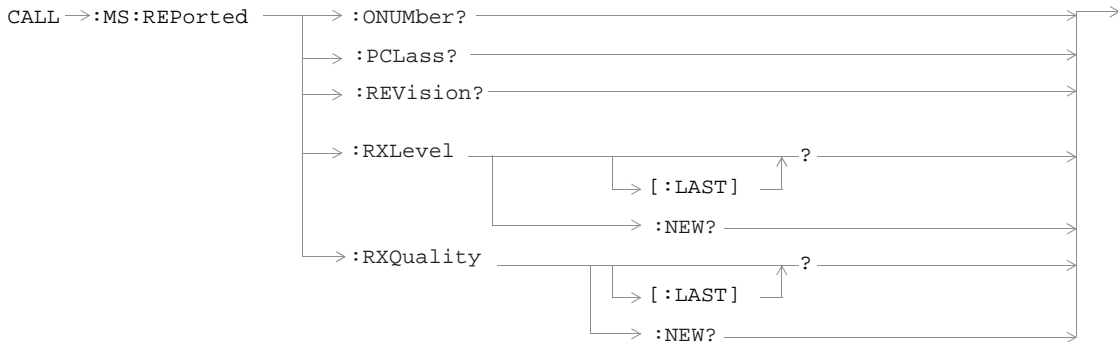

CALL:MS:REPorted<:SBANd? | :TADVance | :TXLevel>

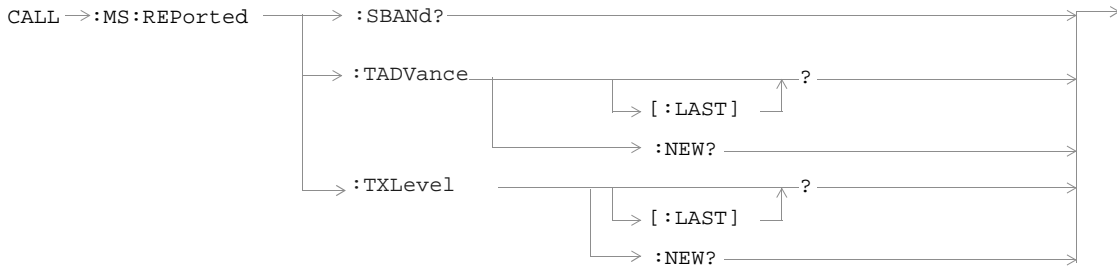

CALL:MS:TADVance

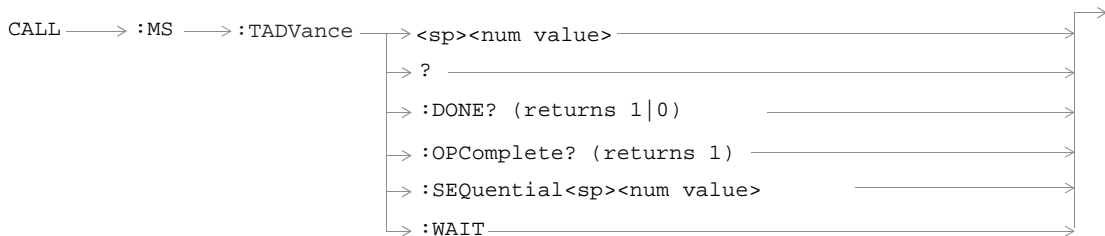

CALL:MS:TXLevel

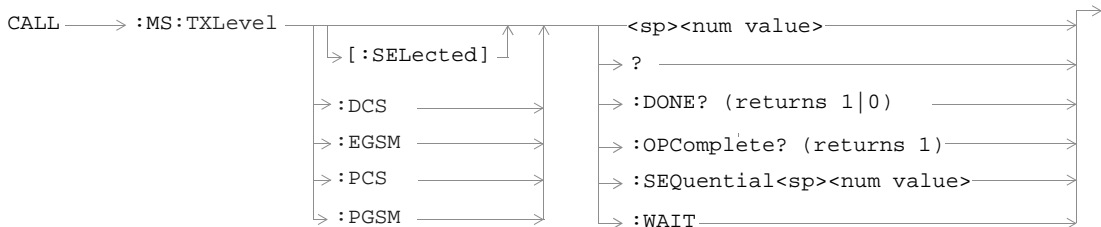

CALL:NCCode

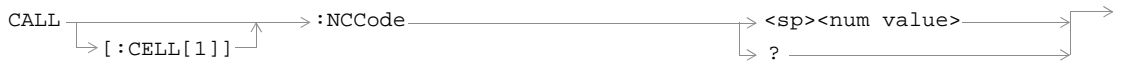

CALL:OPERating

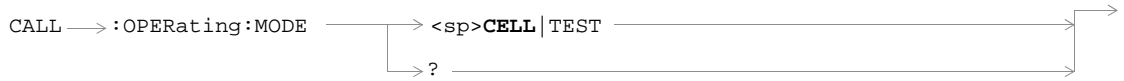

CALL:ORIGinate



CALL:PAGing

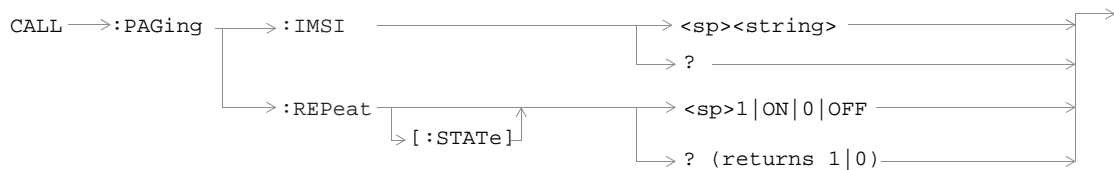

CALL:PMNCode

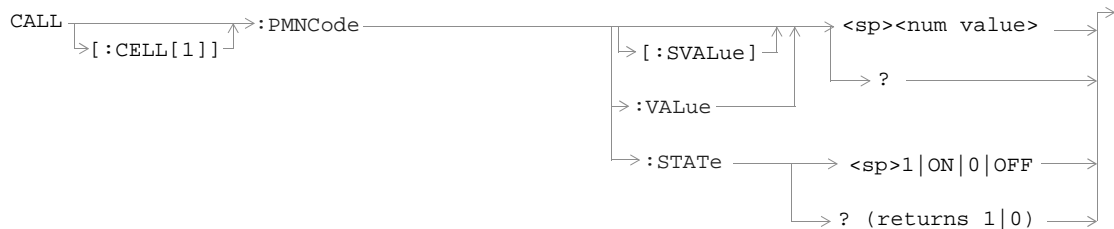

CALL:POWer

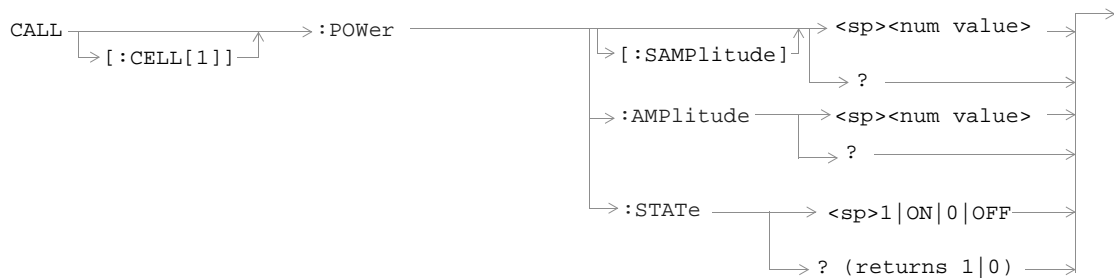

CALL:RFGenerator

CALL:RFGenerator<:CHANnel | :FREQUency>

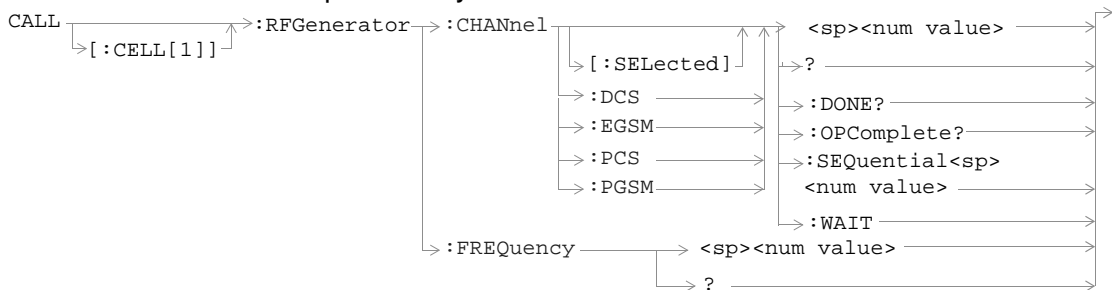

CALL:RFGenerator:POWer

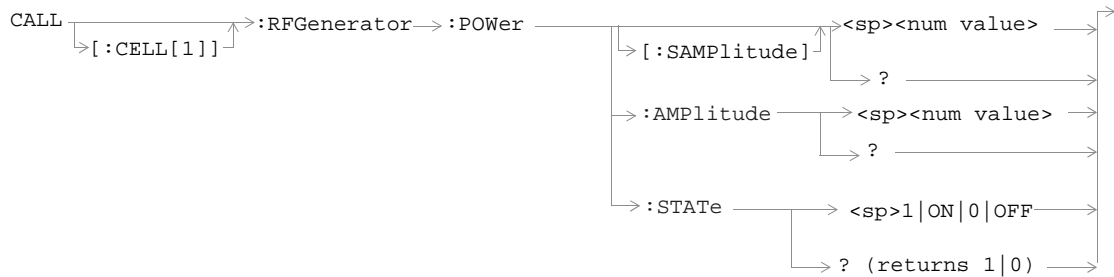

CALL:STaTus

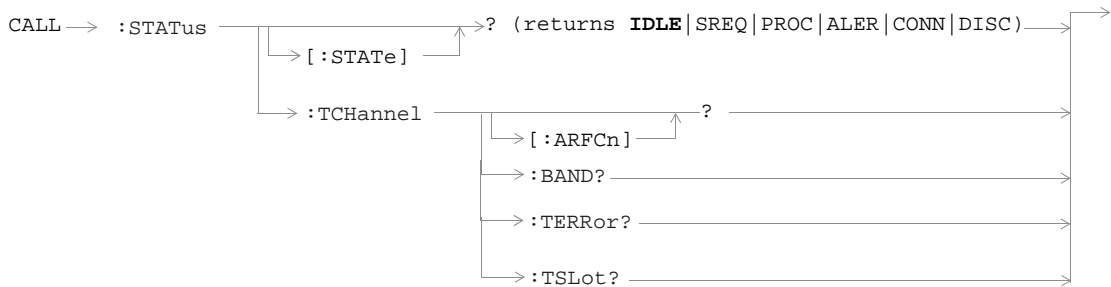

CALL:TCHannel

CALL:TCHannel

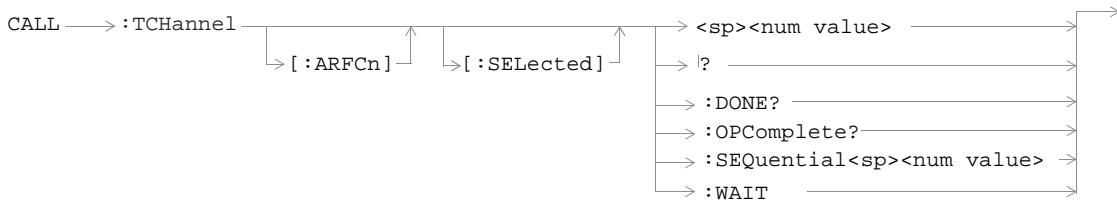

CALL:TCHannel<:DCS | :EGSM | :PCS | :PGSM>

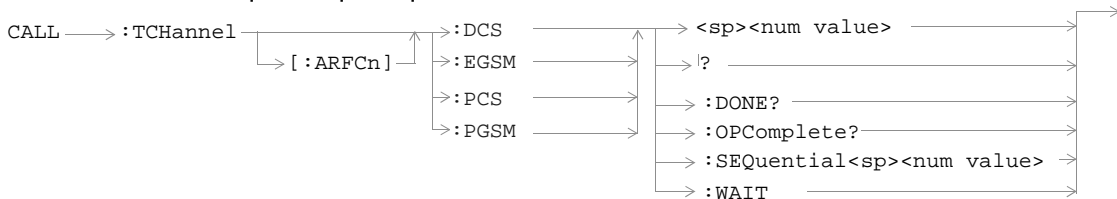

CALL:TCHannel:BAND

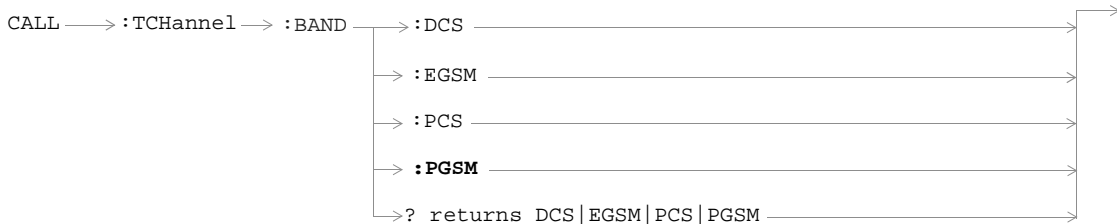

CALL:TCHannel<:DOWNlink | :LOOPback | :TSLot>

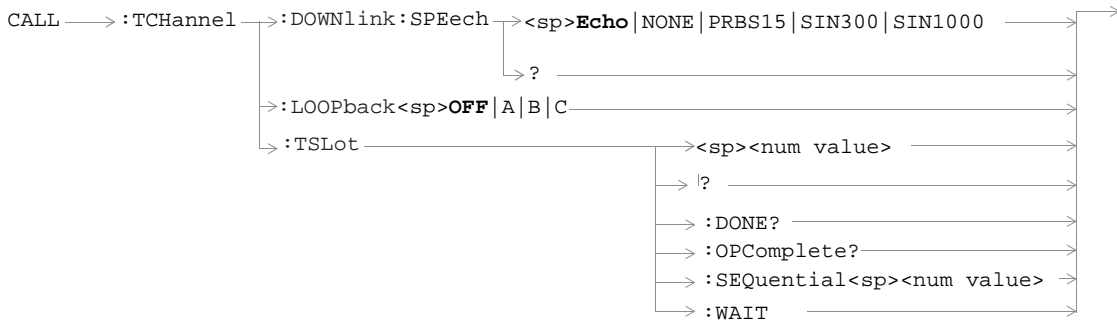

DISPlay

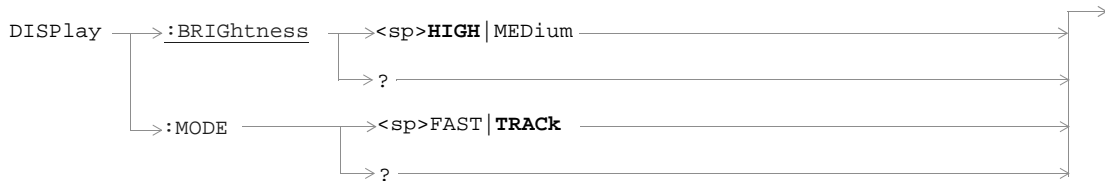

FETCh:AAudio

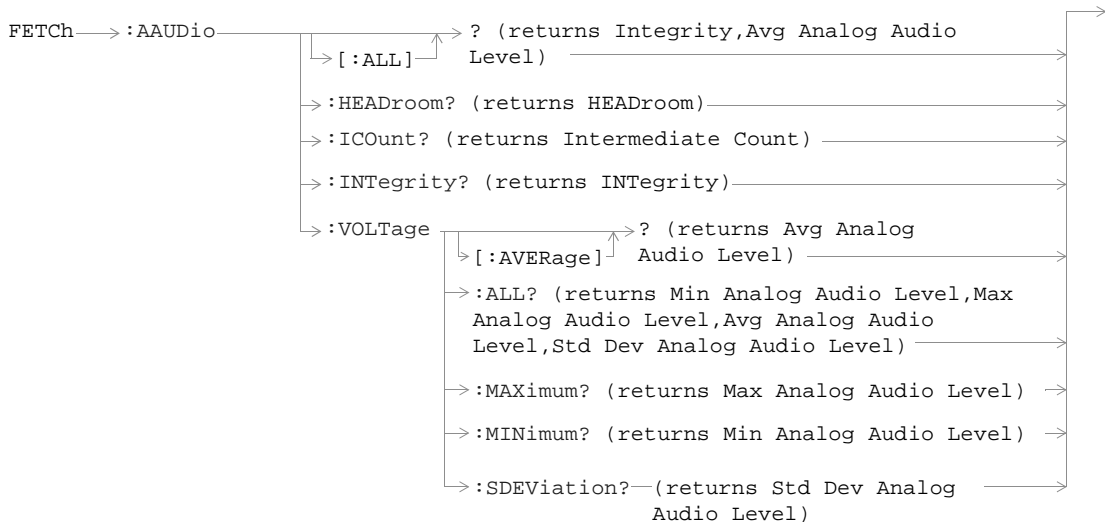

FETCh:BERRor

FETCh:BERRor<:BITS | :DELay | :COunt | :INTegrity>?

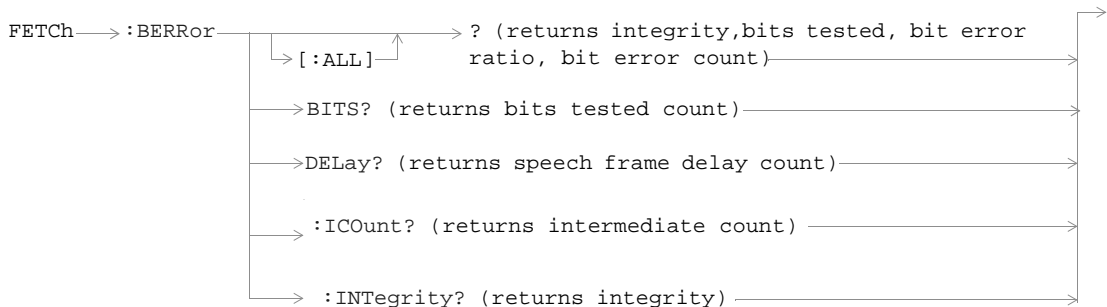

FETCh:BERRor:COUNT

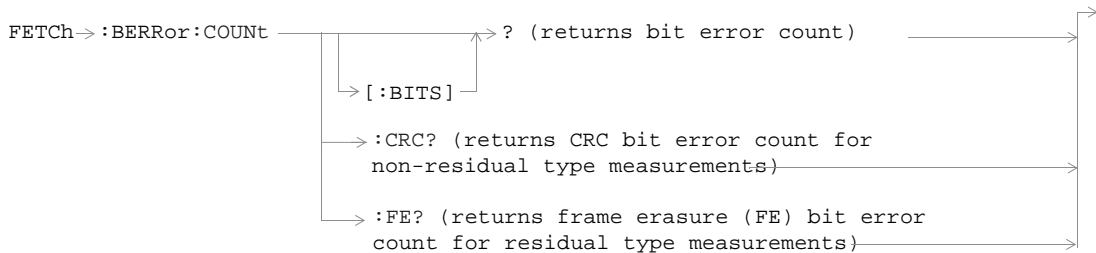

FETCH:BERRor:RATio

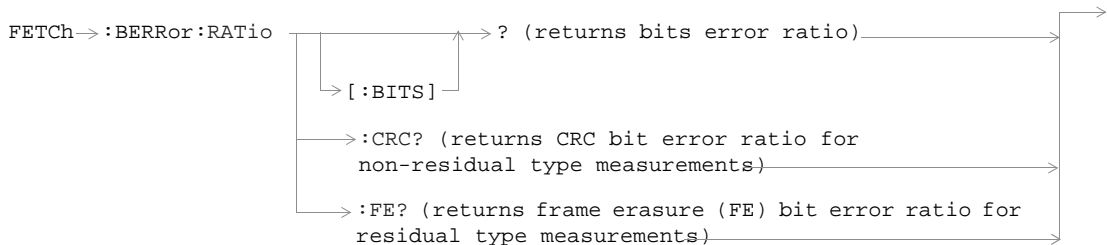

FETCh:DAUDIO

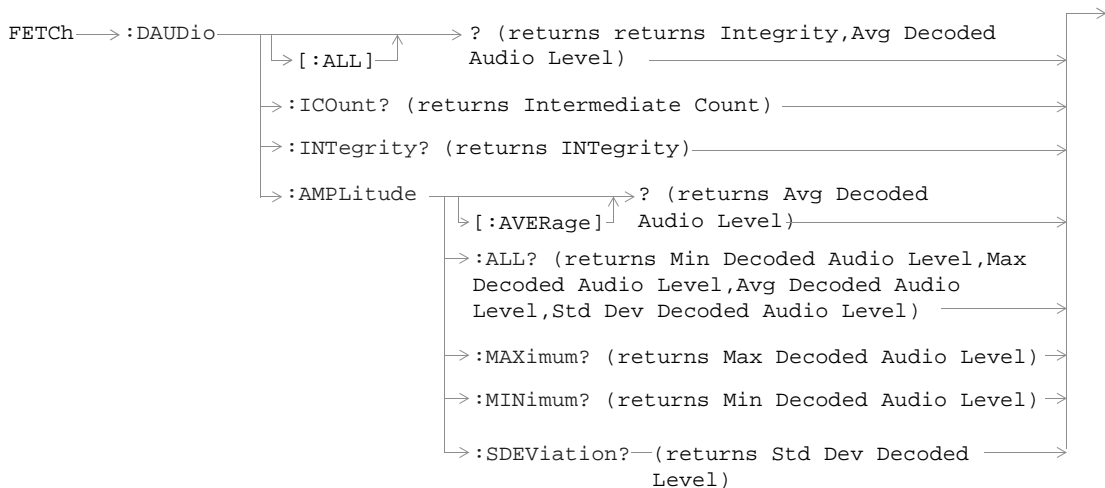

FETCh:FBERror

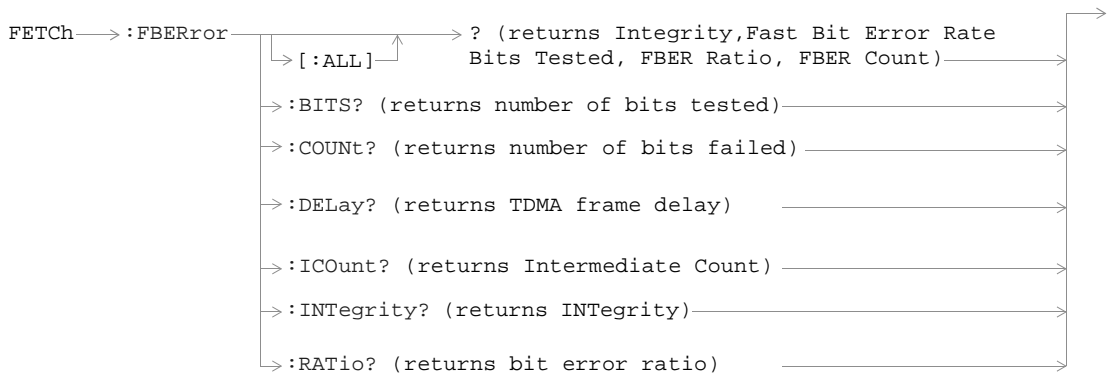

FETCh:ORFSpectrum

FETCh:ORFSpectrum<:ICount | :INTEgrity | :MODulation | :POWER>?

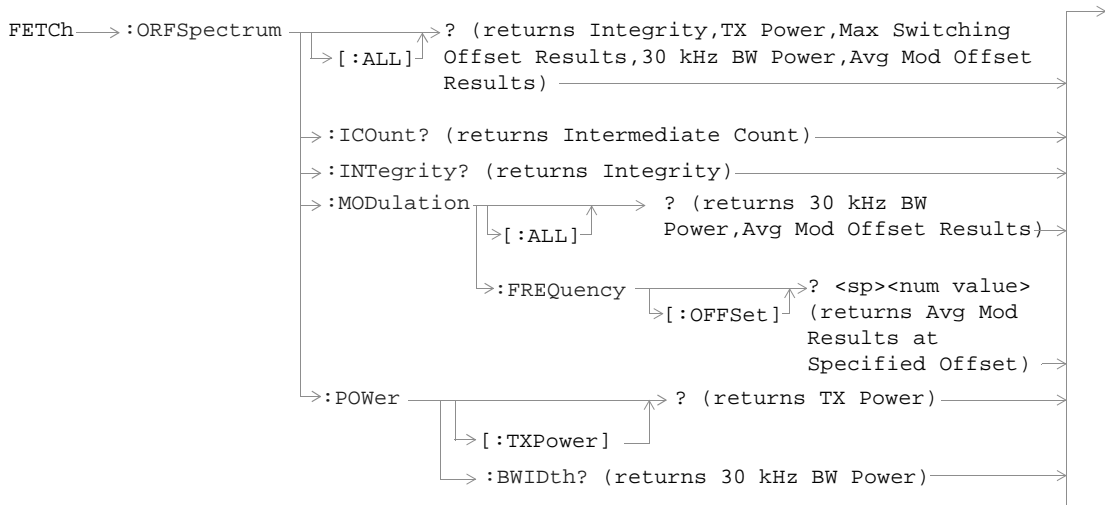

FETCH:ORFSpectrum:SWITching

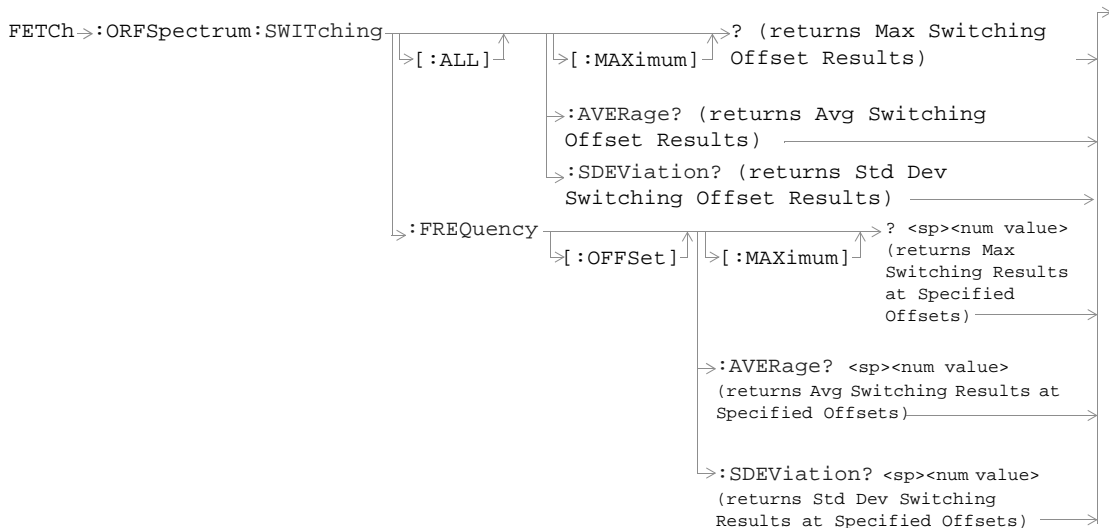

FETCh:PFERror

FETCh:PFERror<:FERRor | :ICount | :INTegrity>?

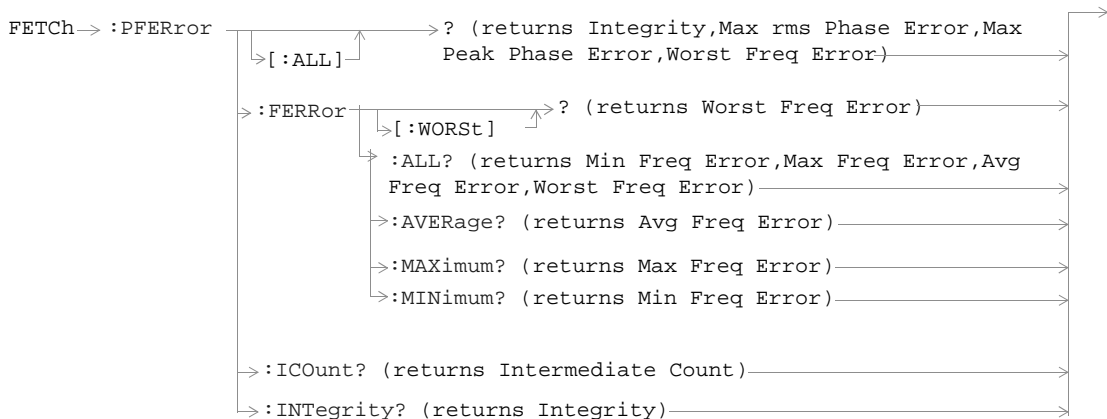

FETCh:PFERror:PEAK

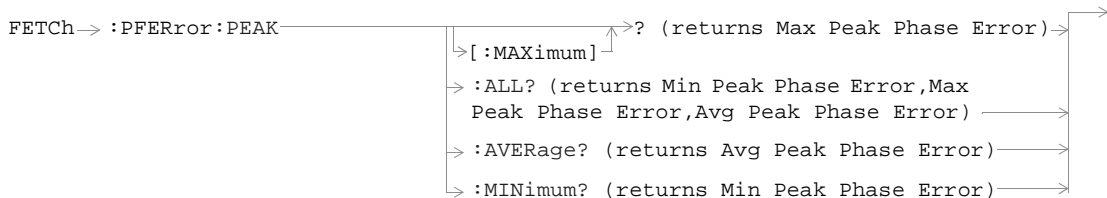

FETCh:PFERror:RMS

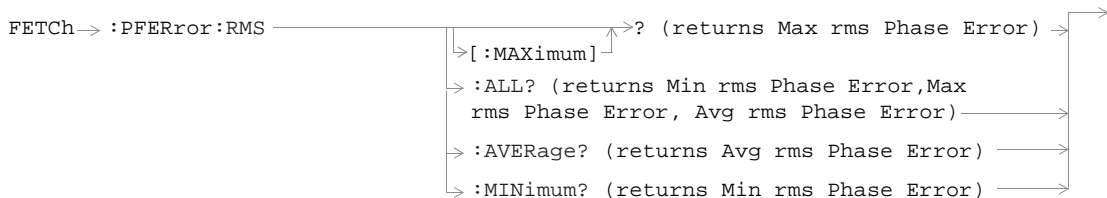

FETCh:PVTime

FETCh:PVTime<:ICount | :INTEgrity>?

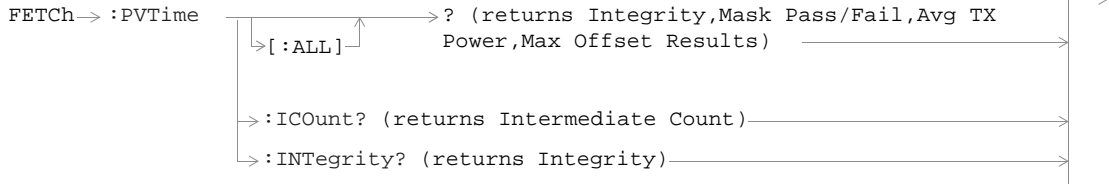

FETCh:PVTime:TXPower

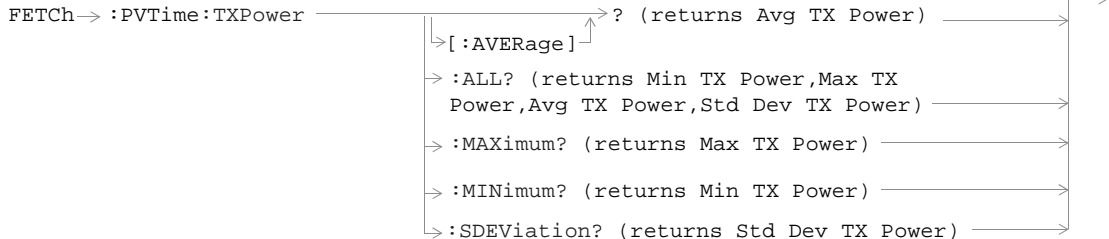

FETCh:PVTime:MASK

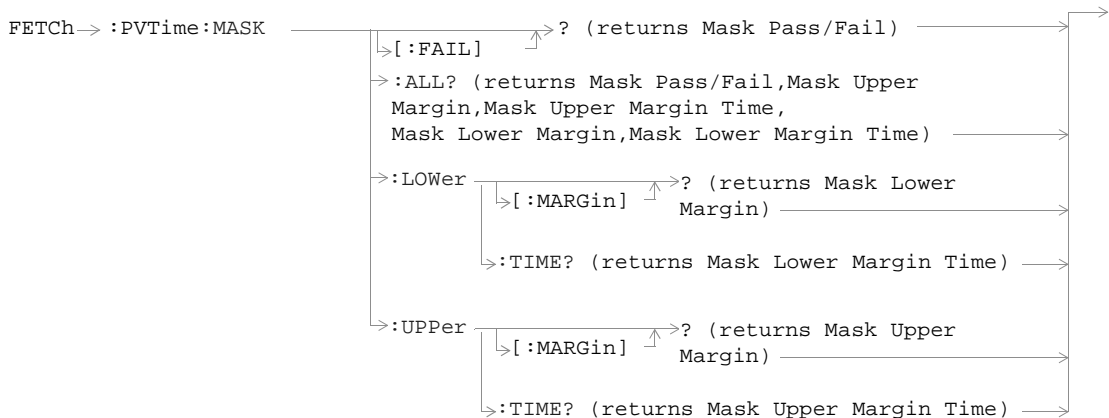

FETCh:PVTime:POWer

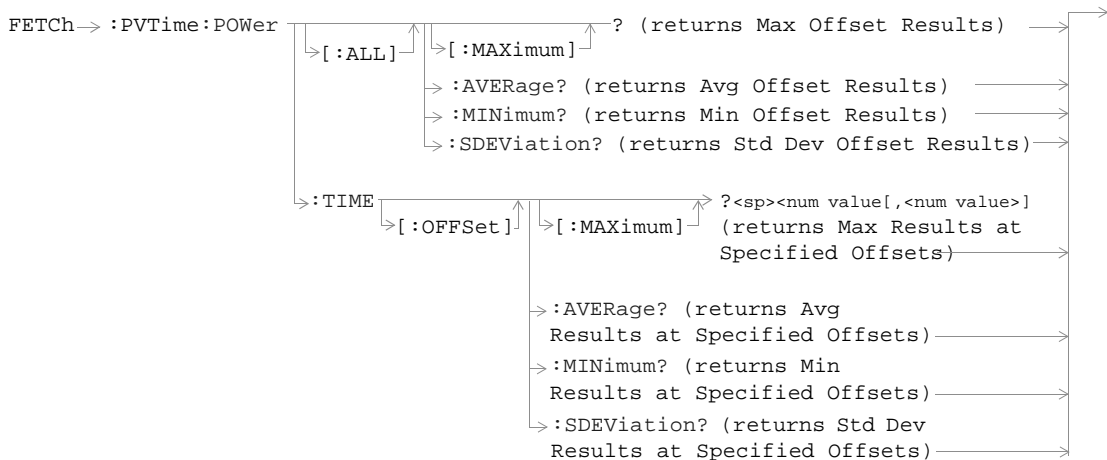

FETCh:TXPower

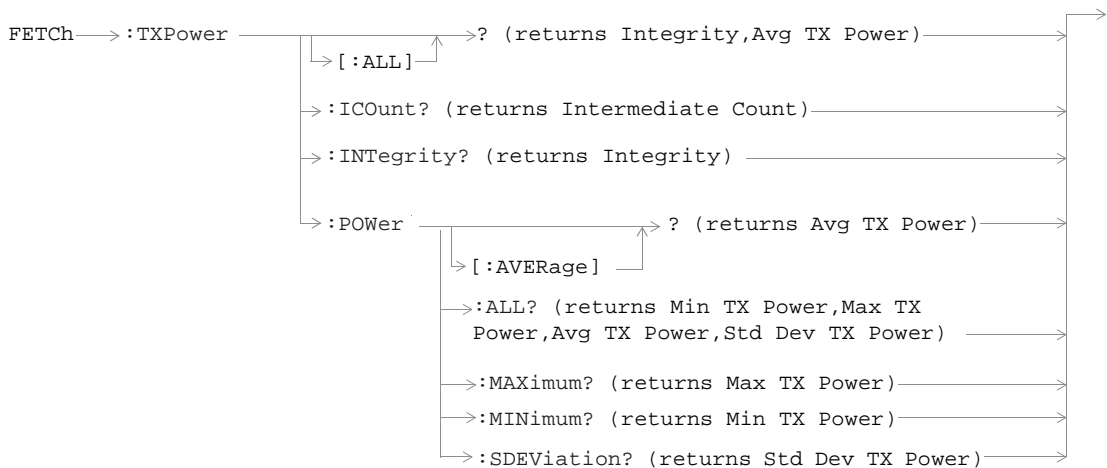

INITiate

INITiate:<measurement mnemonic>

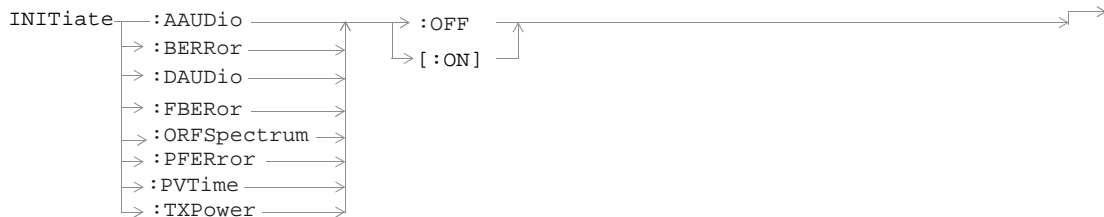

INITiate:<COUNT? | :DONE | :ON?>

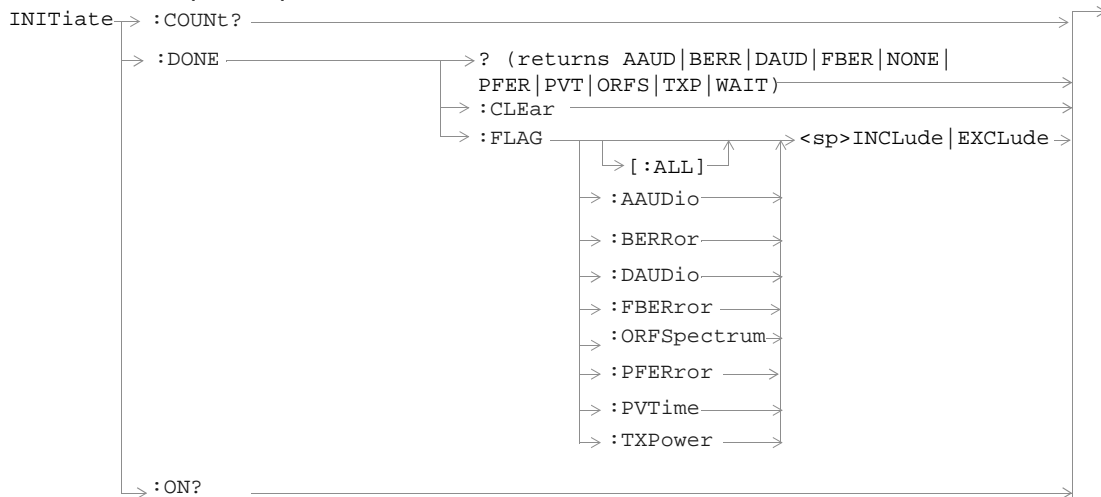

READ

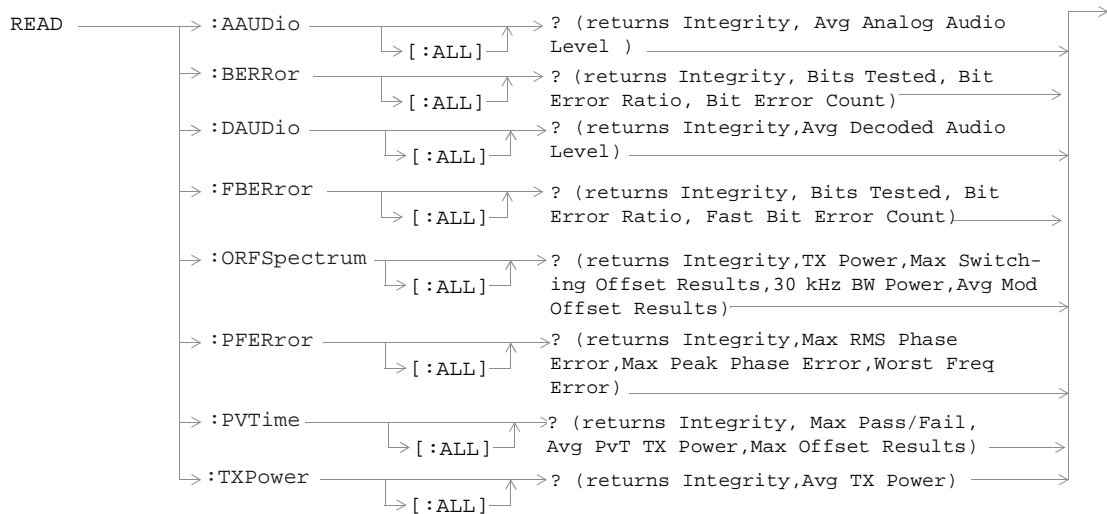

RFAnalyzer

RFAnalyzer:CONTROL



RFAnalyzer:EXPECTed

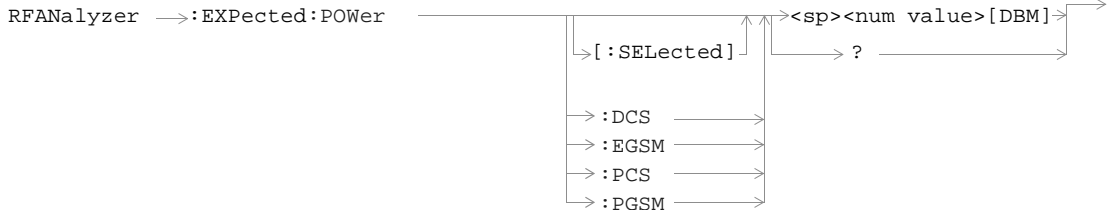

RFAnalyzer:MANual

RFAnalyzer → :MANual

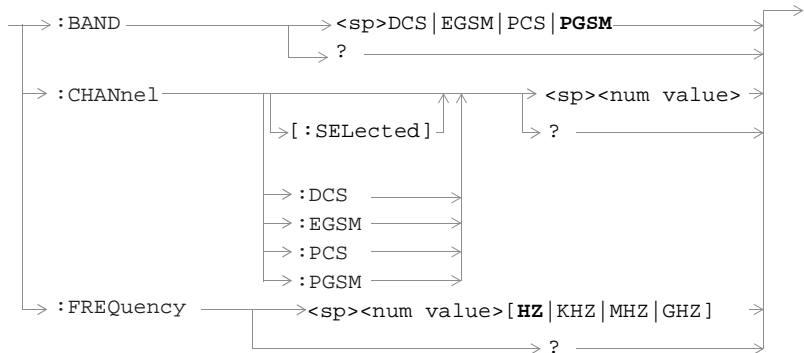

SETup:AAUDio

SETup:AAUDio<:CONTInuous | :COUNT | :EXPEcted>

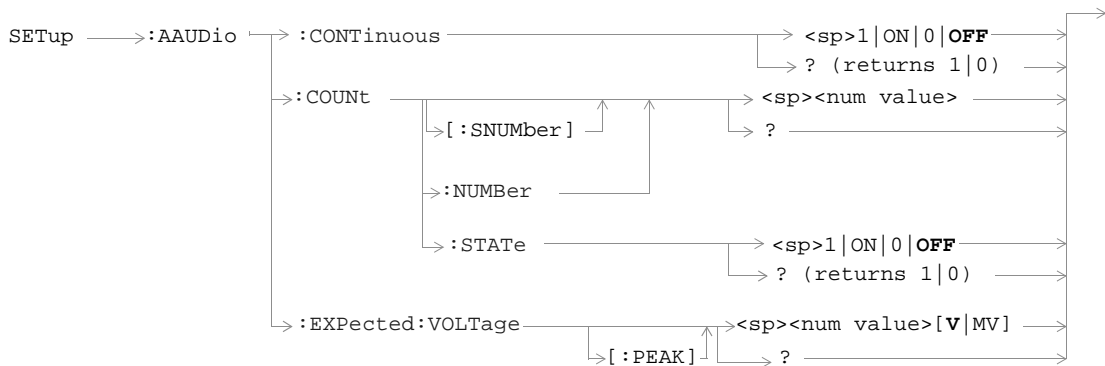

SETup:AAUDio<:FILTer | :TIMEout>

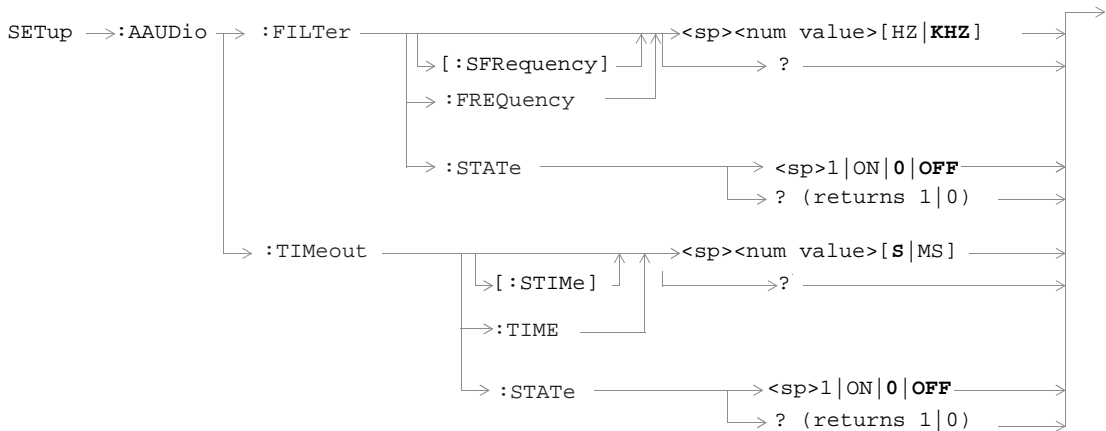

SETup:BERRor

SETup:BERRor<[:TYPE] | :CONTInuous | :COUNt>

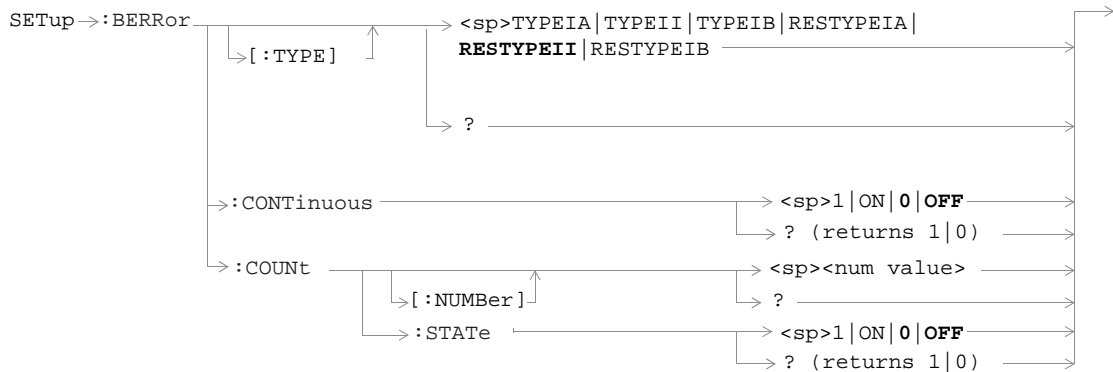

SETup:BERRor<:LDControl | :MANual | :TIMEout>

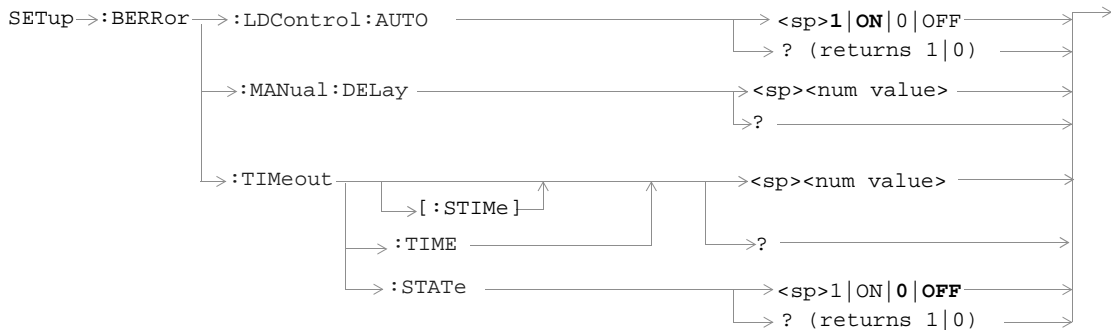

SETup:CONTInuous

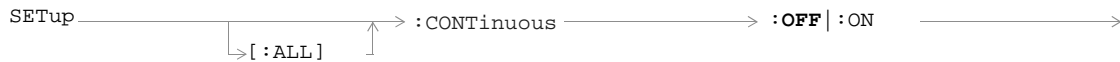

SETup:DAUDio

SETup:DAUDio<:CONTInuous | :COUNT>

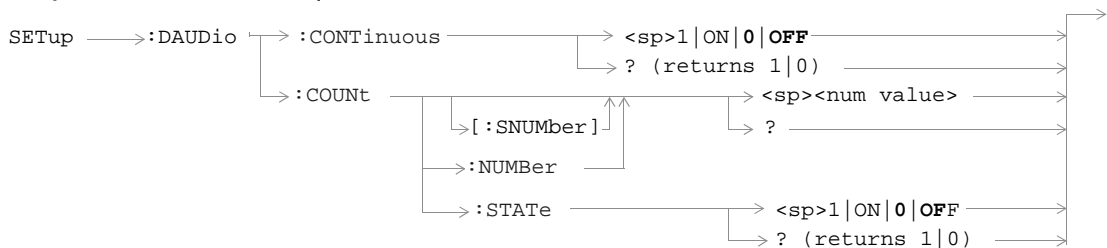

SETup:DAUDio<:FILTer | :TIMEout>

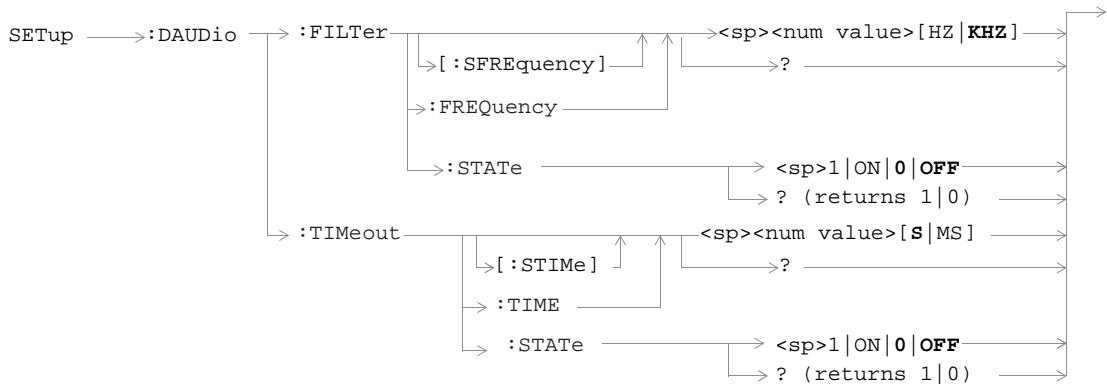

SETup:FBERror

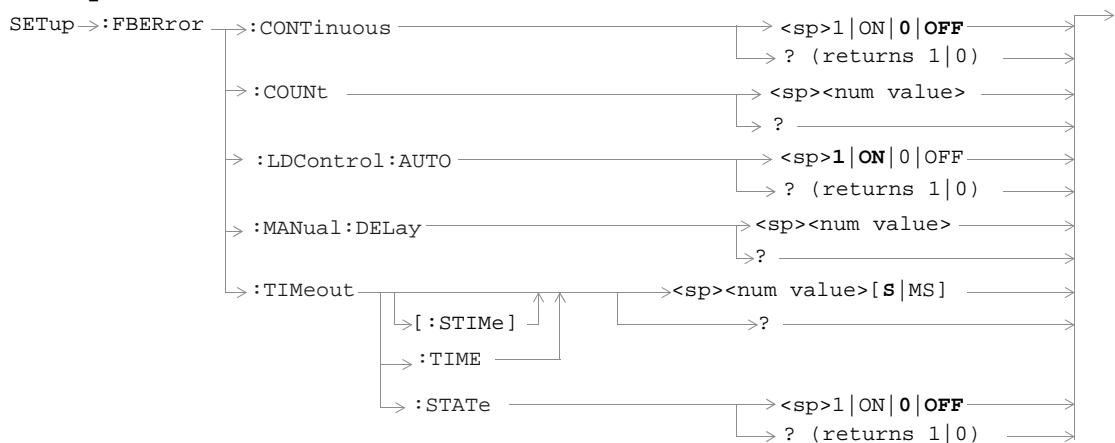

SETup:ORFSpectrum

SETup:ORFSpectrum<:CONTInuous | :COUNT | :ICount>

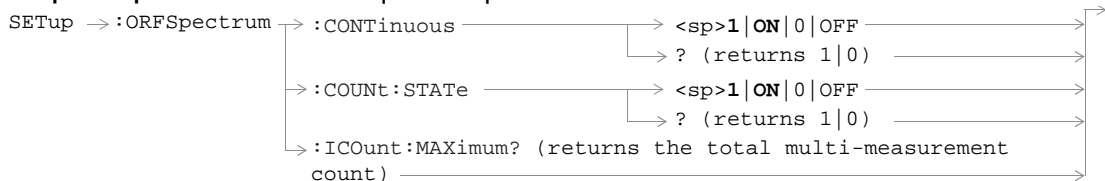

SETup:ORFSpectrum:MODulation

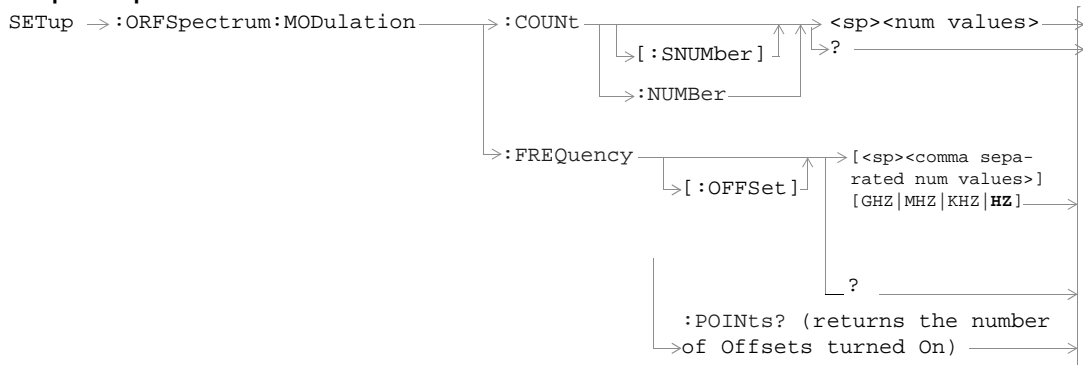

SETup:ORFSpectrum:SWITching

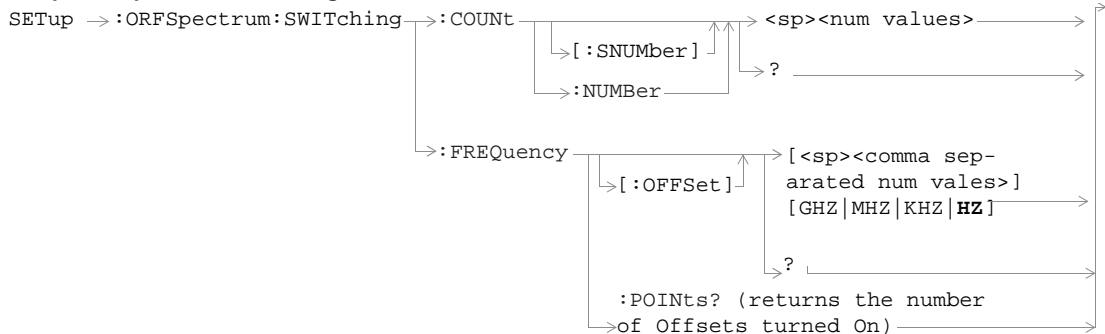

SETup:ORFSpectrum:TIMEout

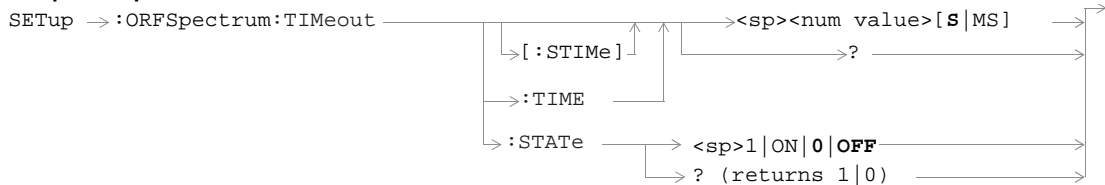

SETup:ORFSpectrum:TRIGger

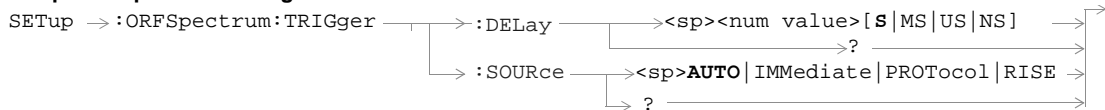

SETup:PFERror

Syntax Diagrams and Command Descriptions

SETup:PFERror<:BSYNc | :CONTInuous | :COUNT>

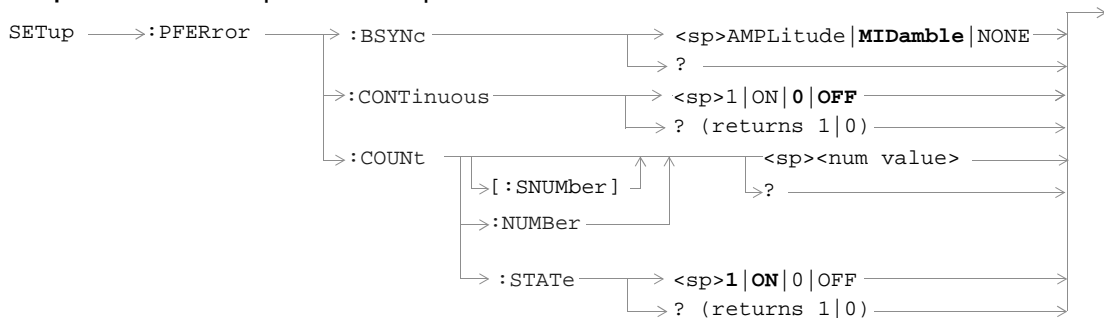

SETup:PFERror:TIMEout

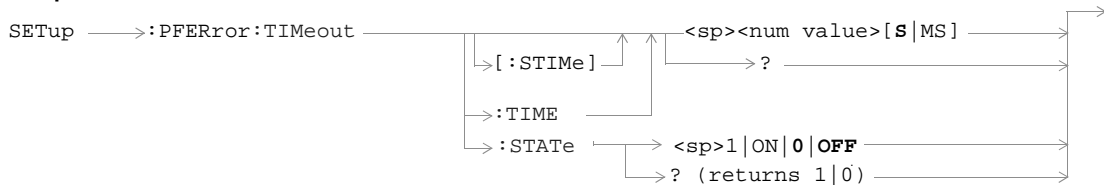

SETup:PFERror:TRIGger

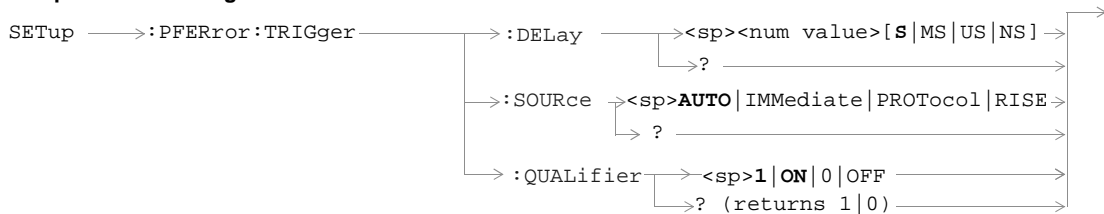

SETup:PVTime

SETup:PVTime<:BSYNc | :CONTInuous | :COUNT>

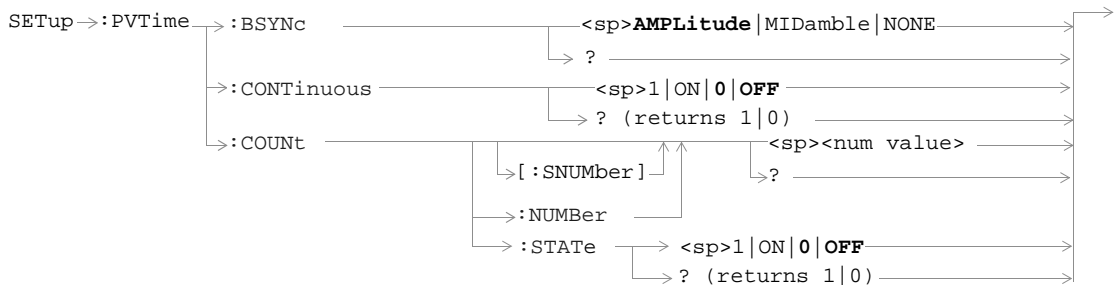

SETup:PVTime:TIME

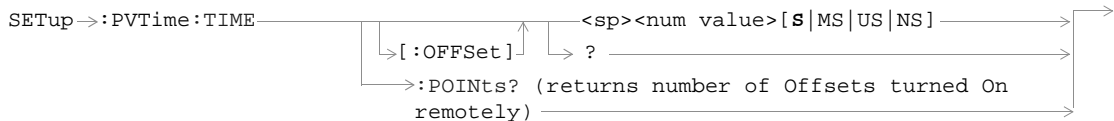

SETup:PVTime:TIMEout

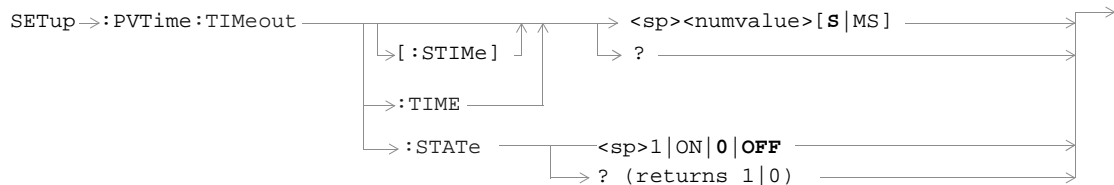

SETup:PVTime:TRIGger

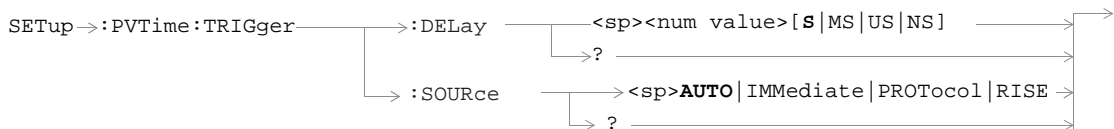

SETup:TXPower

SETup:TXPower<:CONTInuous | :COUNT>

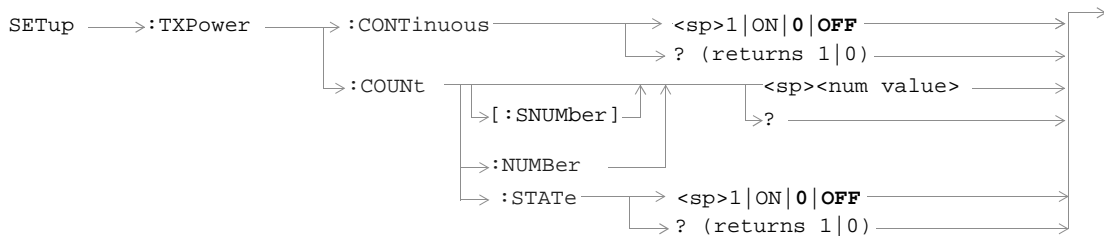

SETup:TXPower:TIMEout

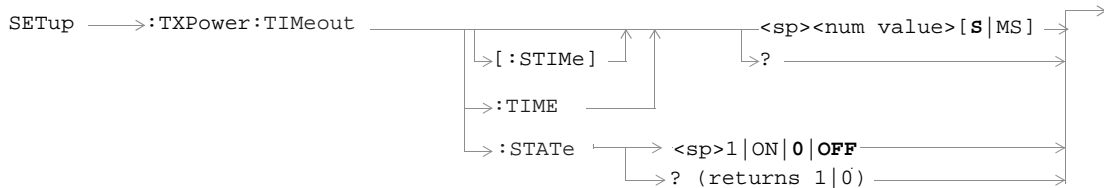

SETup:TXPower:TRIGger

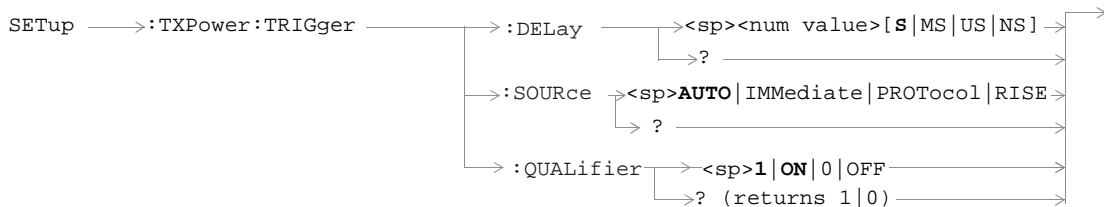

STATUS:OPERation

STATUS:OPERation

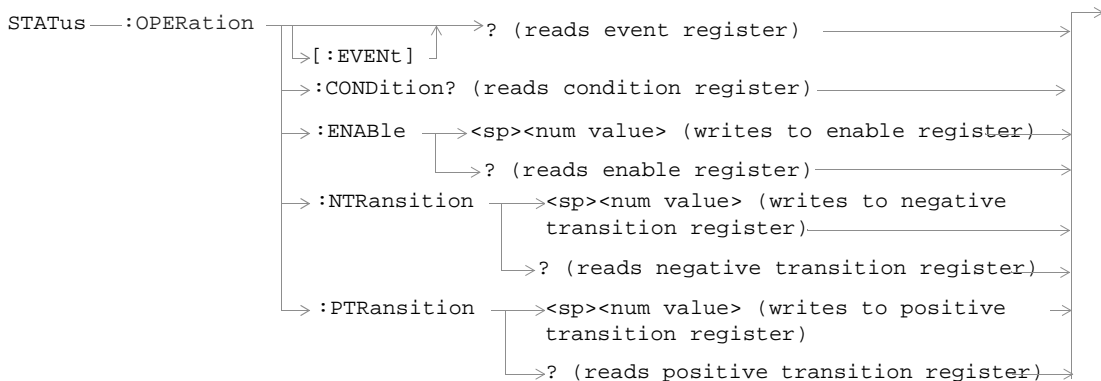

STATUS:OPERation:CALL

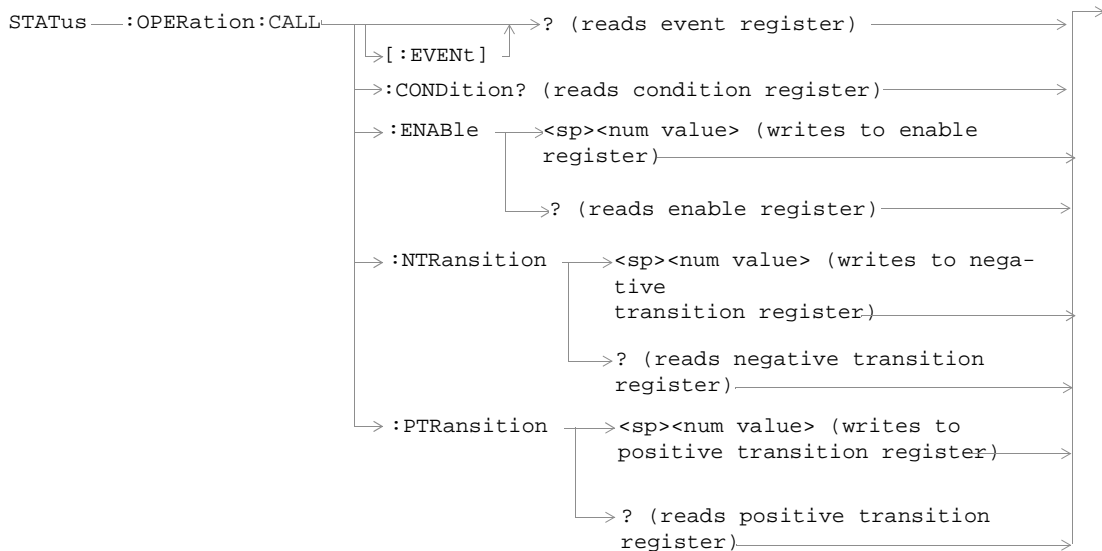

STATUS:OPERation:NMRReady

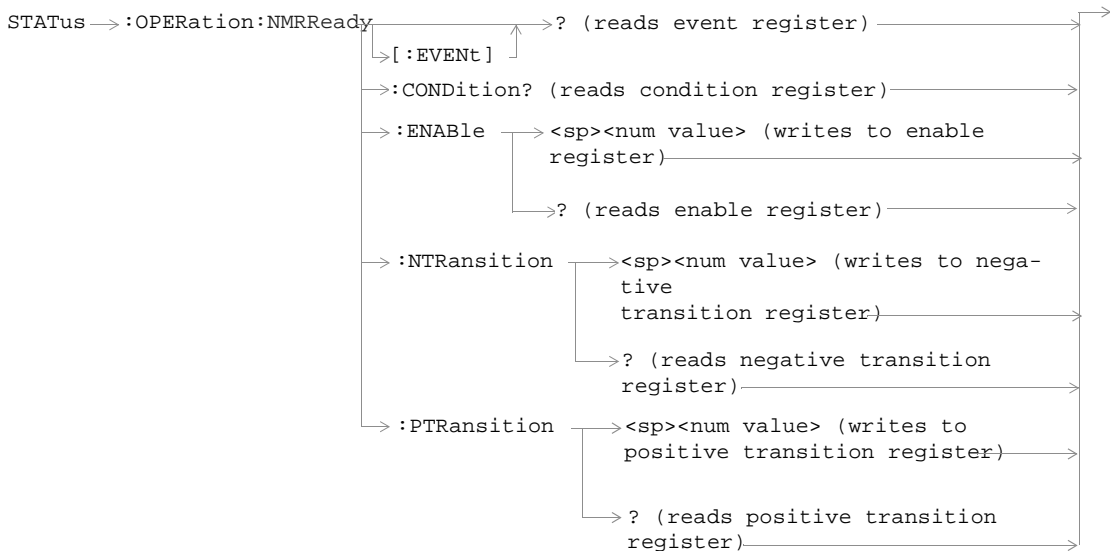

STATus:PRESet

STATus → :PRESet 

STATUS:QUESTIONABLE

STATUS:QUESTIONABLE

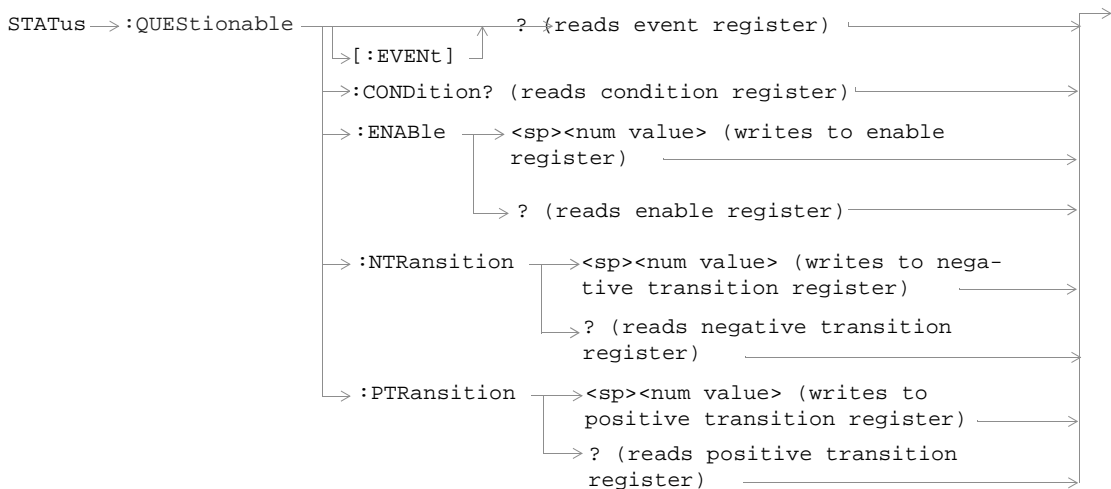

STATUS:QUESTIONABLE:CALL

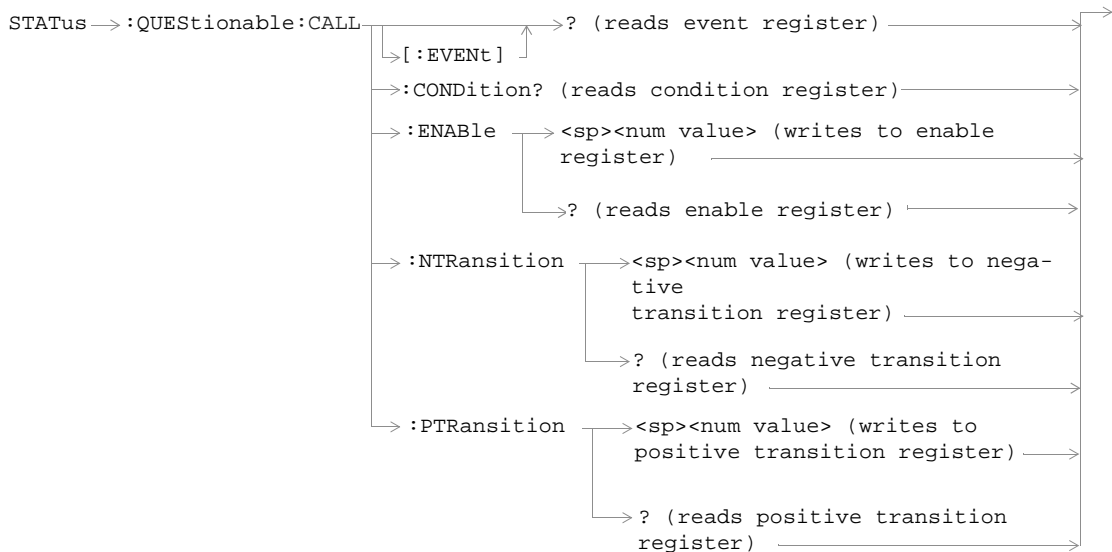

STATUS:QUESTIONABLE:ERRORS

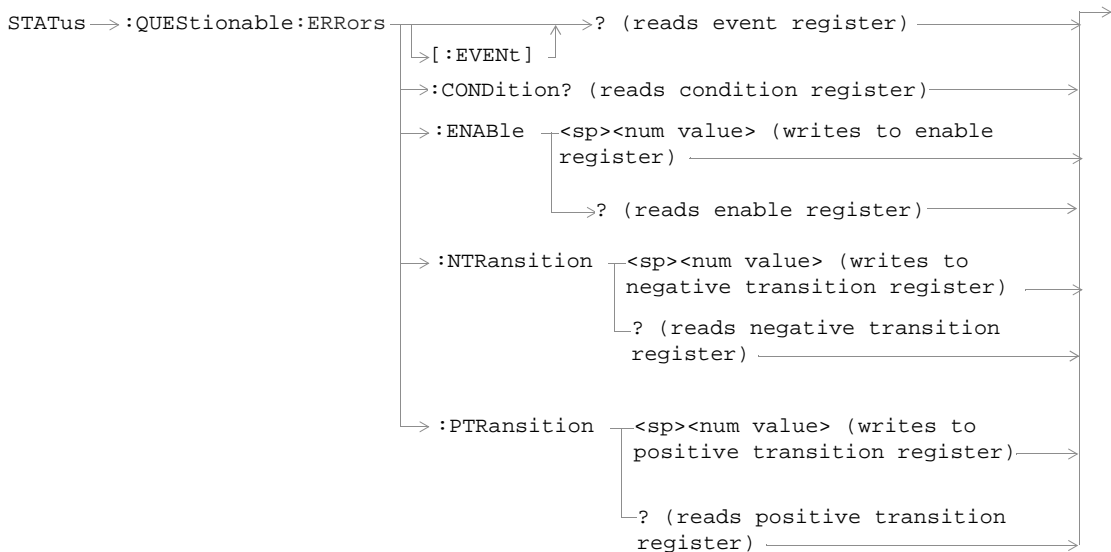

STATUS:QUESTIONABLE:HARDWARE

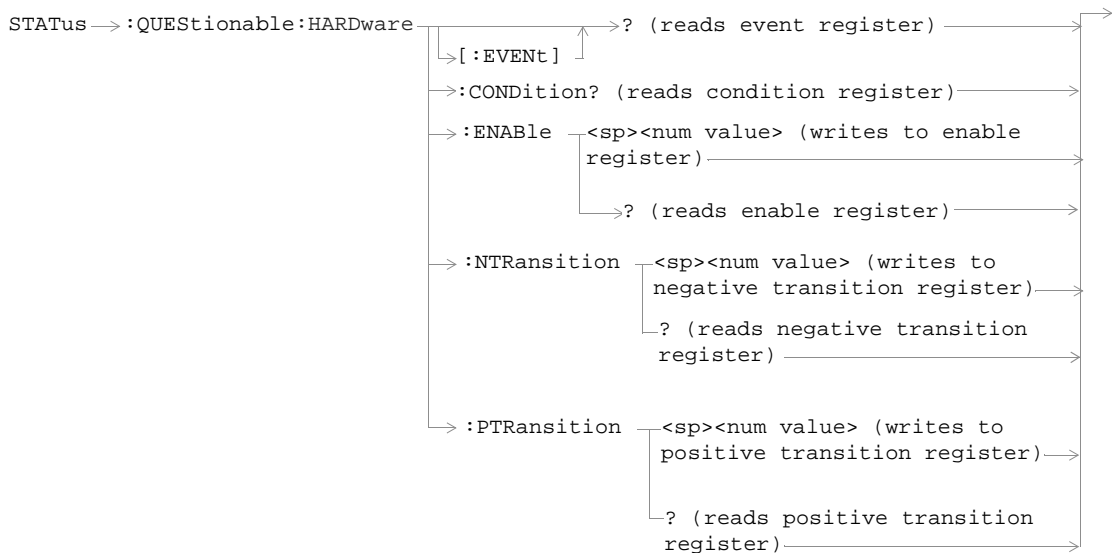

SYSTEM:BEEPer

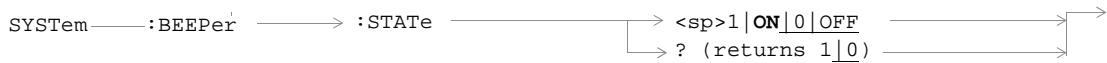

SYSTEM:COMMunicate

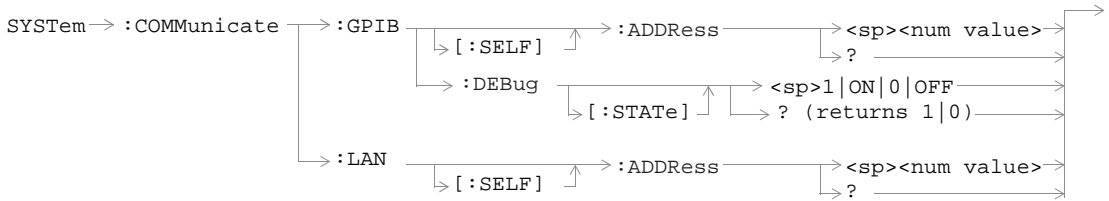

SYSTEM:CORRection

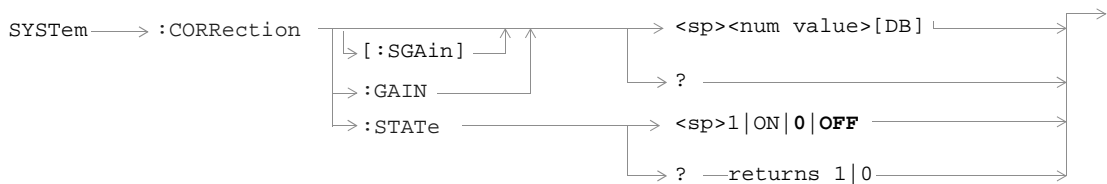

SYSTEM:CURRENT (future functionality)

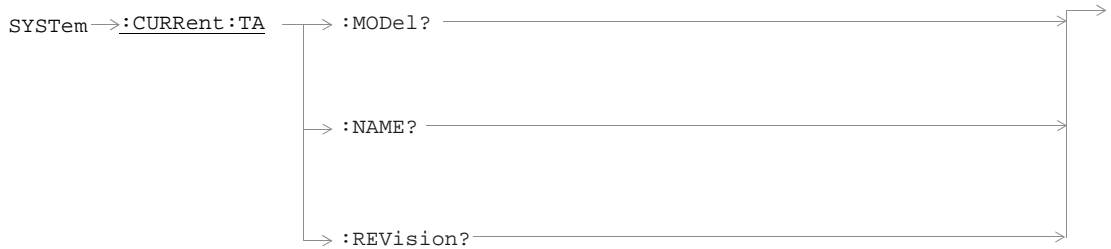

SYSTEM:ERRor

SYSTEM → :ERRor? →

SYSTEM:FTRigger

SYSTEM → :FTRigger

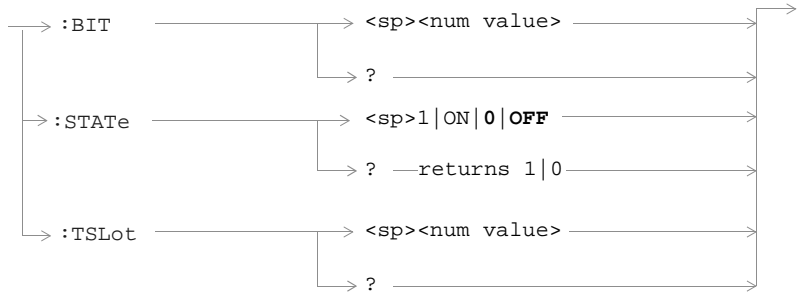

SYSTEM:MEASurement

SYSTEM → :MEASurement:RESet →

SYSTEM:PRESet

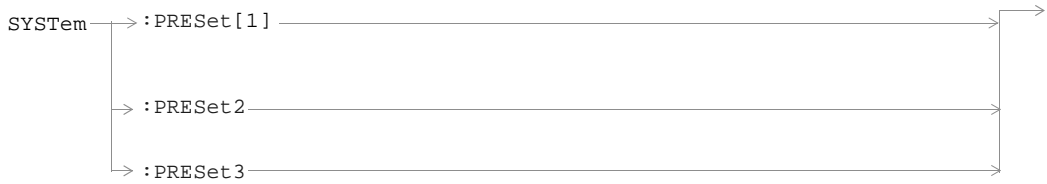

SYSTEM:ROSCillator

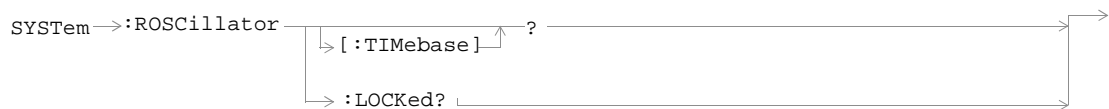

SYSTEM:SYNChronized



HP-IB IEEE 488.2 Common Commands

****CLS** on page 104

****ESE** on page 104

****ESE?** on page 104

****ESR?** on page 104

****IDN?** on page 104

****OPC** on page 105

****OPC?** on page 105

****OPT?** on page 105

****RST** on page 106

****SRE** on page 107

****SRE?** on page 107

****STB?** on page 107

****WAI** on page 107

***CLS**

The *CLS, clear status command, is defined in “IEEE Std 488.2-1992”, 10.3. This command will also clear and close the error message screen on the test set’s display.

***ESE**

The *ESE, standard event status enable command, is defined in “IEEE Std 488.2-1992”, 10.10.

***ESE?**

The *ESE?, standard event status enable query, is defined in “IEEE Std 488.2-1992”, 10.11.

***ESR?**

The *ESR?, standard event status register query, is defined in “IEEE Std 488.2-1992”, 10.12.

***IDN?**

The *IDN?, identification query is defined in “IEEE Std 488.2-1992”, 10.14. *IDN? is used to retrieve information about the test set in ASCII format. (See .)

*IDN?, returns ASCII codes 32 through 126 excluding comma and semicolon in four comma separated fields. Field 1 returns the manufacturer, field 2 returns the instrument model number, field 3 returns the serial number, field

4 returns 0.

For revision information on the currently installed test application, see “SYSTEM:CURRENT (future functionality)” on page 96.

***OPC**

The *OPC, operation complete command, is defined in “IEEE 488.2-1992”, 10.18. *OPC causes the test set to continuously sense the No Operation Pending flag. When the No Operation Pending flag becomes TRUE, the OPC event bit in the standard event status register (ESR) is set to indicate that the state of all pending operations is completed. The *OPC common command is not recommended.

***OPC?**

The *OPC?, operation complete query, is defined in “IEEE Std 488.2-1992”, 10.19. The *OPC? query allows synchronization between the controller and the test set using either the message available (MAV) bit in the status byte, or a read of the output OPC?. The *OPC? query does not effect the OPC event bit in the Standard Event Status Register (ESR). The *OPC? common command is not recommended.

***OPT?**

The *OPT?, option identification query, is defined in “IEEE Std 488.2-1992”, 10.20. Each option will have a unique name, that name will be returned with the query.

***RST**

The *RST command is defined in “IEEE Std 488.2-1992”, 10.32. The *RST command is a full preset, which restores a majority of settings to their default values. See .

Affects of Sending the *RST Command

- All pending operations are aborted.
- Measurement triggering is set to single.
- Any previously received operation complete command (*OPC) is cleared.
- Any previously received operation complete query (*OPC?) is cleared.
- The power-up self-test diagnostics are not performed.
- The contents of the save/recall registers are not affected.
- Calibration data is not affected.
- The HP-IB interface is not reset (any pending service request is not cleared).
- All enable registers are unaffected: service request, standard event, communicate, hardware #1, hardware #2, operation, calibration, and questionable data/signal.
- All negative transition filter registers are unaffected: communicate, hardware #1, hardware #2, operation, calibration, and questionable data/signal.
- All positive transition filter registers are unaffected: communicate, hardware #1, hardware #2, operation, calibration, and questionable data/signal.

- The contents of the RAM memory are unaffected.
- The contents of the output queue are unaffected.
- The contents of the error queue are unaffected.

***SRE**

The *SRE, service request enable command, is defined in “IEEE Std 488.2-1992”, 10.34. The parameter range for this command is 0 through 255.

***SRE?**

The *SRE?, service request enable query, is defined in “IEEE Std 488.2-1992”, 10.35. Values returned by this query range from 0 through 255.

***STB?**

The *STB?, read status byte query, is defined in “IEEE Std 488.2-1992”, 10.36. Values returned by this query range from 0 through 255.

***WAI**

The *WAI, wait-to-continue command, is defined in “IEEE Std 488.2-1992”, 10.39. The *WAI command prevents the test set from executing any further commands or queries until all pending operation flags are false. The *WAI

common command is not recommended.

Syntax Equivalents

To find a syntax equivalent for a field on the Test Set's display.

1. Find the field name on the Test Set's display.
2. Look up the name in the alphabetical listing.
3. Turn to the page indicated.

Numerics

3 Digit MNC for PCS 1900, 39

A

Active Cell Status, 43
Analog Audio Setup, 67

B

BA States, 17
BA Table, 17
Band Pass Filter Frequency, 68
BCC (Base Station Colour Code), 20
Broadcast Chan, 21
Burst Synchronization
 PFER, 79
Burst Synchronization
 PVT, 81

Burst Timing Error, 43

C

Called Number, 32, 33
Cell Activated State, 16
Cell Band, 19
Cell Power, 40
Cell Power State, 40
Corrupted Bursts, 24

D

Decode Errors, 24

E

End Call, 25
Expected Audio Amplitude, 67
Expected Band, 65
Expected Burst, 22
Expected Channel, 65
Expected Freq, 65
Expected Power, 65

G

Get IMEI at Call Setup, 27

I

IMEI, 32, 33
IMSI, 32, 33

L

LAC, 32, 33
LAC (Location Area Code), 28

M

Max Frames Allowed for Assignment, 24
MCC, 32, 33
MCC (Mobile Country Code), 29
Measurement Offsets
 PVT, 81
Measurement Timeout
 PVT, 82
 TXP, 83
Missing Bursts, 24
MNC, 32, 33
MNC (Mobile Network Code), 30
Mobile DTX State, 31
Mobile Loopback, 44
Modulation Offset
 ORFS, 76
Modulation Offset #
 ORFS, 76
MS TX Level, 34
Multi-Measurement Count
 AAUD, 67
 ORFS, 75
 PFER, 79
 PVT, 81
 TXP, 83
Multi-Measurement Count (Modulation)

Syntax Equivalents

ORFS, 76
Multi-Measurement Count (Switching)
ORFS, 77

N

NCC (Network Colour Code), 35

O

Operating Mode, 36
ORFS Setup, 75
Originate Call, 37

P

Pages, 24
Paging IMSI, 38
Phase & Freq Setup, 79
Power Class, 32, 33
Power vs Time Measurement Setup, 81

R

RACHs, 24
Receiver Control, 65
Repeat Paging, 38
Revision Level, 32, 33
Rx Level, 32, 33
Rx Qual, 32, 33

S

Supported Band, 32, 33
Switching Offset
ORFS, 77

T

Time Offset
PVT, 81
Timeslot, 44
Timing Adv, 32, 33
Timing Advance, 34
Traffic Channel, 44
Trigger Arm
AAUD, 67
ORFS, 75
PFER, 79
PVT, 81
TXP, 83
Trigger Delay
ORFS, 78
PVT, 82
TXP, 84
Trigger Qualifier
TXP, 84
Trigger Source
ORFS, 78
PVT, 82
TXP, 84
Tx Level, 32, 33
TX Power Setup, 83

U

Use 3 Digit MNC for PCS 1900, 39